



PREMIUM-WERKZEUGE



PREMIUM TOOLS



www.kstools.com

PULLER

SAFETY AND USAGE INSTRUCTIONS

Removing components may require very high forces. The use of a puller involves risks that should not be underestimated. Therefore great care must be observed and attention given to safety during each pulling process.

- Prior to commissioning, read through the operating instructions thoroughly and obtain advice from the manufacturer's application consultancy service if anything is unclear.
- Before use, learn about the correct employment of the tool to be used, taking into account the safety measures required.
- Apply pullers securely and monitor the forces that occur during the pulling procedure. If there are signs of overloading for example stiffness - break off pulling procedure immediately and use a larger puller or if necessary another puller model.
- Check the application of force on spindle drives with a torque wrench and on pump-driven, hydraulic puller tools using a pressure gauge. Never exceed the torque and load information on manufacturers' nameplates, in operating instructions or tables.
- Do not use electrical or pneumatic force or impact wrenches to operate pulling tools.
- The use of an extension to increase the transferred torque on the active tool can lead to overload and thus to breakage.
- **Caution:** The load and torque details are to be determined in the laboratory with new pullers and pulling equipment under normal conditions of use. Wear and tear caused by use and unfavourable usage circumstances can negatively influence the values.
- **Important:** The performance capacity of a combination piece of equipment, such as a puller with a hydraulics system, always depends on the weakest element.
- During the pulling procedure, always cover the danger zone, puller/part to be pulled, with an accident protection tarpaulin, in order to avoid injuries.
- Warming up the component is one method of positively influencing the pulling procedure.
Caution: In the process, the puller should never be warmed, as otherwise its strength characteristics can be negatively influenced.
- Check state of the puller tool prior to any use and immediately replace damaged, manipulated or worn parts.
- Keep spindle threads or traverses clean and well-oiled.
- Regular maintenance lengthens the lifespan of the equipment, protects against accidents and ensures that the puller tool is ready for use.
- Make no alterations whatsoever to the puller tools. Any alteration may lead to dangerous consequences for the operator and automatically results in the expiry of the guarantee claim.
- In accordance with the UVV (Accident Prevention Regulations) or country-specific legislation, always wear prescribed personal protective equipment such as safety shoes, helmet, protective goggles, gloves, etc.



PREVENTIVE ACCIDENT PROTECTION MEASURES

Accident protection tarpaulin covers

During pulling work there are typically very powerful forces which can jerk components loose or even cause parts to break off or splinter from the pulling object. Parts flying around out of control represent a potential danger to the life and limb of the operator. Our accident protection tarpaulins were developed to effectively eliminate this danger.

The tarpaulins consist of particularly highly-elastic, tear-resistant and oil-resistant special material and will be tautened prior to the pulling procedure around component and puller.

To ensure that it is still possible to properly monitor and control the pulling procedure, the tarpaulins are transparent.

When the working area is being enclosed, the tarpaulins will be securely fastened and held in position with worked-in belts.



General safety instructions

During the pulling procedure as few people as possible should be in the puller's working area.



During the pulling procedure, always position yourself at the side and not in the puller's pulling axis. If the component comes loose abruptly, it can lead to the puller shooting away.

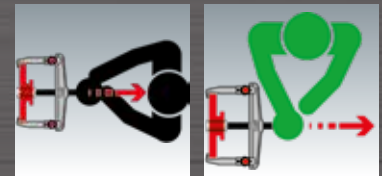

If necessary secure the puller against falling or uncontrolled motion away, after successful loosening of the component, with chain or belt, etc.

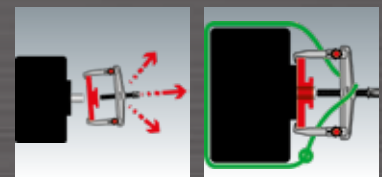

In accordance with the UVV (accident-prevention regulations) or country-specific legislation always wear prescribed, personal protective equipment, e.g. safety shoes, helmet, protective goggles, gloves, etc.



SMALL PULLING PRIMER

Selection of the puller according to the work task

Inquire about:

type of component	bearing / belt pulley / gear wheel / bushes etc.
diameter of the component	selection of the work area
pulling depth	selection of the arm length
gripping options on the component	external puller / internal puller / special puller
spatial conditions	standard puller or slim design / 2-arm or 3-arm
support options on the component	on the central axle (spindle) / outside of the housing (bridge yoke) / no support option (slide hammer)

In general, the model determined in this way will exhibit the required characteristics. Regardless of this, however, the largest possible model should always be used as safety must always be paramount here.

Insofar as spatial conditions permit, a three-armed variant should always be preferred to a two-armed variant. Three-armed pullers have a better load distribution of the pulling force than two-armed pullers. This ensures easy, secure and even pulling.

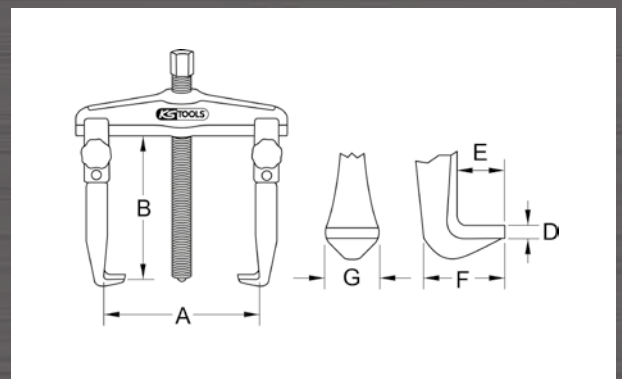
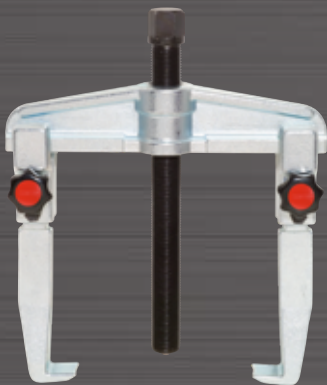

Diameter and pulling depth from the table directly at the item

Torque and max. load

	A mm	B mm	max. load t	key mm	mm	D mm	E mm	F mm	G mm	kg	
620.1701	20-90	100	70	5	M14x1,5 x 130	17	3	13	25	20	1,00
620.1702	25-130	100	80	5	M14x1,5 x 130	17	3	13	25	20	1,20
620.1703	30-160	150	90	6,5	G1/2"x14g x 210	22	4	16	35	25	3,00
620.1704	50-160	150	100	6,5	G1/2"x14g x 210	22	4	16	35	25	3,30
620.1705	60-200	150	110	11	G3/4"x14g x 280	27	5	25	54	35	7,40
620.1706	80-350	160-420	110	11	G3/4"x14g x 280	27	5	25	54	35	8,50

max. torque	max. load t	max. load t
30	2	2
40	2,5	2,5
70	4	4
605.0114	90	5

External puller

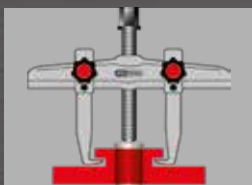

Internal puller



Puller and extractor



Separation equipment

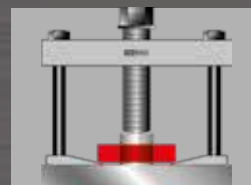

Special puller

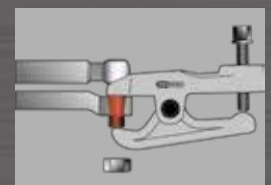

CORRECT PLACEMENT OF A PULLER

When pulling from belt pulleys, gear wheels, flanges, etc. the puller arm should always be placed as close as possible in the direction of the centre (at the shaft) (between the spokes / at a collar, etc.). With large components in particular the direct application of force in the base area is significantly more effective than on the external diameter and the dimensions of the traverse / arm can be smaller.

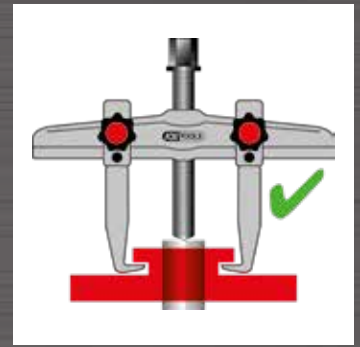
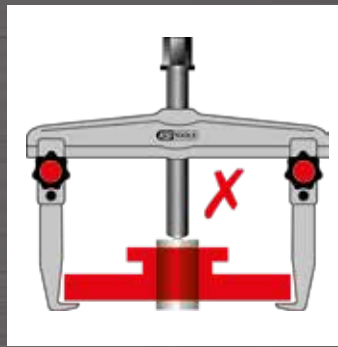

Components lying flush require tapered gripping elements, such as a knife (e.g. slitting knife/internal extractor/separating puller). To ensure the gripping elements have an optimal and secure fit, after a brief, powerful pull of the working spindle the puller should be loosened again, in order for the clamping element to then be able to clamp again. This allows the gripping elements to get an even better rear grip.

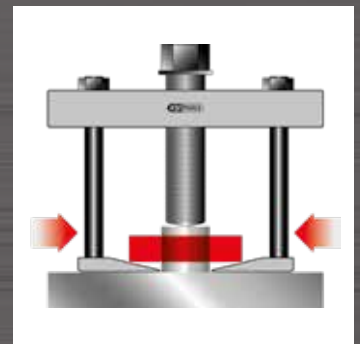
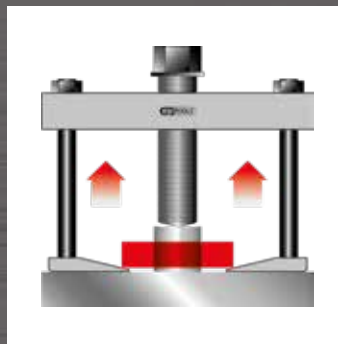

Place the puller arm carefully and ensure that the puller sits precisely in the pulling axis.

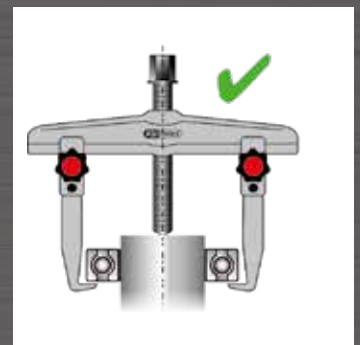
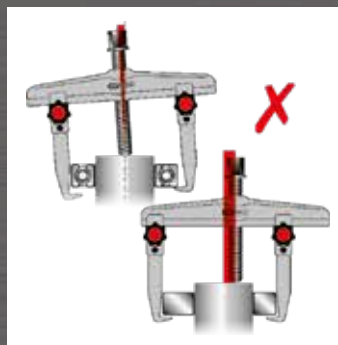

Insofar as spatial conditions permit, a three-armed variant should always be preferred over a two-armed variant. Three-armed pullers have a better load distribution of the pulling force than two-armed pullers. This ensures easy, secure and even pulling.

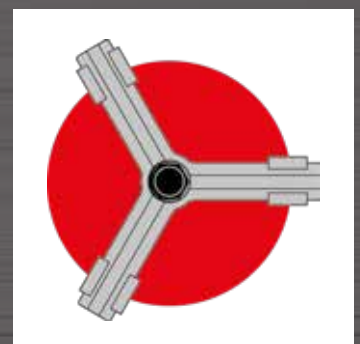
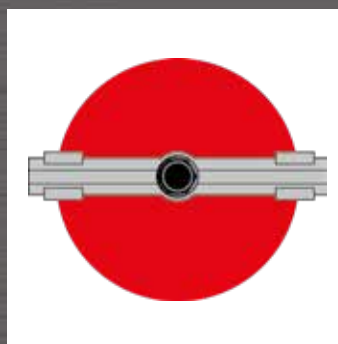

Before the pulling procedure remove everything that would prevent the unobstructed outwards movement of the part to be pulled. (wedges, screws, flanges, nuts, dowel pins, etc.)

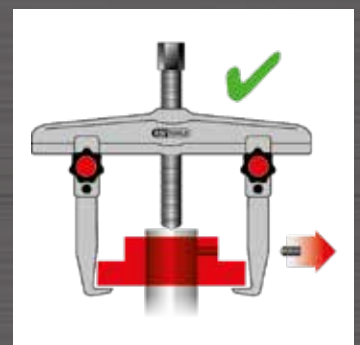
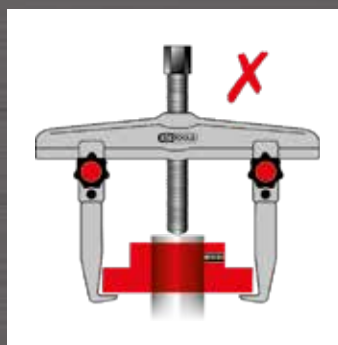

USE OF THE CORRECT DRIVE TOOLS

Torque wrench

To achieve optimal work results, it is necessary to monitor the application of force to mechanical spindle drives with a suitable torque wrench. On the next page is a table with technical data such as information on the maximum input torque at the drive spindle and the maximum load-bearing capacity of the puller. Note that this input torque is to be measured in such a way that the maximum draw-off strength can be achieved. Therefore avoid extending the drive tools as this may lead to overload and thus to breakage. The torque tools listed below are of matched perfectly in type and design to the usage requirements of all KS Tools pullers and correspond to the DIN EN 6789 standards.



ERGOTORQUE® precision torque wrench with rotary button reversible ratchet head

- Release accuracy: $\pm 3\%$ tolerance from set scale value
- Repeat-accurate and precise for at least 5,000 load reversals
- for controlled clockwise and counterclockwise operation
- with ribbed knob at the reversal square for manual pulling
- The direction of operation is changed by reversing the drive square
- Double scale in Nm and lbf·ft division for precise setting
- including finely divisible Nm micrometer scale for fine and precise setting
- large viewing window with magnifying function optimises readability
- clearly audible and palpable torque release through close-gap release
- with robust 30-tooth ratchet mechanism
- Torque-setting quickly and safely by turning the handle
- secure locking option on the handle
- ergonomic and hand-friendly 2-component grip with soft zone
- square drive in accordance with DIN 3120 - ISO 1174 with ball-locking device
- individual series number for clear product identification
- including certificate in accordance with DIN EN ISO 6789:2003 - traceable to national standard

1/4" 3/8" 1/2"



	■	N·m	lbf·ft	Division N·m	L mm	D mm	H mm	kg
516.1412	1/4"	5 - 25	0,8 - 18	0,10	289,0	35,0	18,0	0,46
516.1422	3/8"	10 - 50	4 - 37	0,25	350,0	45,0	23,0	0,61
516.1432	1/2"	20 - 100	8 - 75	0,50	412,0	45,0	23,0	0,91
516.1442	1/2"	40 - 200	15 - 150	1,00	500,0	45,0	23,0	1,30
516.1472	1/2"	60 - 320	45 - 236	1,00	585,0	45,0	23,0	1,45
516.1482	1/2"	80 - 420	60 - 310	1,00	678,0	45,0	23,0	2,10

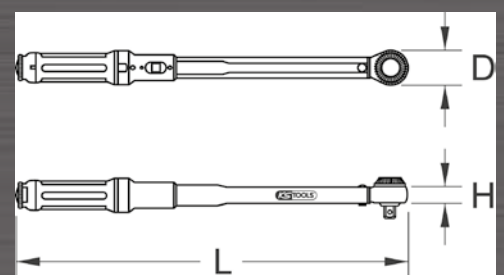

DRIVE TORQUES AND MAXIMUM TENSILE FORCE

(1 t = 1 Mp = 10KN)

	max. Torque Nm	max. t		max. Torque Nm	max. t		max. Torque Nm	max. t		max. Torque Nm	max. t
150.2075	200	6	620.0107	360	13	620.3102	20	1,2	630.3002	70	4,5
150.2130	-	10	620.0108	400	18	620.3103	24	2	630.3101	20	1,2
150.2145	300	-	620.0301	60	12	620.3401	50	3,5	630.3102	21	1,3
150.2146	300	-	620.0302	60	12	620.3402	60	4	630.3103	40	2,5
150.2250	200	6	620.0303	60	12	620.3601	20	2,5	630.3401	60	4
150.2350	300	-	620.0304	60	12	620.3602	50	3,5	630.3402	70	4,5
150.3130	35	2,5	620.0305	60	12	620.3603	60	4	630.3601	25	3
150.3170	35	2,5	620.0306	60	12	620.3604	120	6	630.3602	60	4
152.1005	100	-	620.0307	70	15	620.3605	120	6	630.3603	70	4,5
152.1006	100	-	620.0501	80	4,5	620.3606	120	6	630.3604	220	12
152.1007	100	-	620.0502	80	4,5	620.3607	120	6	630.3605	220	12
152.1008	100	-	620.0503	150	6,5	620.3608	120	6	630.3606	220	12
152.1010	100	-	620.0504	150	6,5	620.3609	120	6	630.3607	220	12
152.1012	100	-	620.0505	320	11	620.3610	120	6	630.3608	220	12
152.1014	100	-	620.0506	320	11	620.3801	60	12	630.3609	220	12
152.1080	30	1,5	620.0507	360	13	620.3802	60	12	630.3610	220	12
152.1100	100	-	620.0508	320	11	620.3803	60	12	630.3801	60	12
152.1101	100	-	620.0509	320	11	620.3804	60	12	630.3802	60	12
450.0000	700	15	620.0510	360	13	620.3805	60	12	630.3803	60	12
450.0001	700	15	620.0511	320	11	620.3806	60	12	630.3804	60	12
450.0002	700	15	620.0512	320	11	620.4101	25	2,5	630.3805	60	12
450.0003	700	15	620.0513	360	13	620.4102	35	3	630.3806	60	12
450.0004	700	15	620.0701	60	12	620.4103	45	3,5	630.3807	60	12
450.0050	60	10	620.0702	60	12	620.4301	25	2,5	630.4101	25	2,5
450.0051	450	10	620.0703	60	12	620.4302	35	3	630.4102	35	3
450.0060	300	-	620.0704	60	12	620.4303	45	3,5	630.4103	45	3,5
450.0061	600	-	620.0705	60	12	620.4304	50	4	630.4301	25	2,5
450.0062	600	-	620.0706	60	12	620.5201	25	1,5	630.4302	35	3
450.0070	170	7	620.0707	60	12	620.5202	60	3,5	630.4303	45	3,5
450.0071	170	7	620.0708	60	12	620.5203	80	4,5	630.4304	50	4
450.0075	220	-	620.0709	60	12	620.5301	18	1	640.0110	-	10
450.0076	220	-	620.0710	60	12	620.5302	35	2	640.0120	-	15
450.0085	700	10	620.0711	60	12	620.5401	120	5	640.0130	-	17
450.0120	-	20	620.0901	80	4,5	620.5402	120	6	640.0140	-	10
450.0126	-	20	620.0902	80	4,5	620.5403	150	8	640.0150	-	20
450.0300	280	-	620.0903	150	6,5	620.5501	120	5	640.0160	60	8
450.0305	280	-	620.0904	150	6,5	620.5502	120	6	640.0165	70	15
500.8610	100	2,5	620.1101	80	4,5	620.5503	150	8	640.0170	-	20
605.0111	30	2	620.1102	80	4,5	630.0101	90	5,5	640.0180	-	30
605.0112	40	2,5	620.1103	150	6,5	630.0102	90	5,5	640.0190	-	50
605.0113	70	4	620.1104	150	6,5	630.0103	180	7	640.0210	-	10
605.0114	90	5	620.1301	60	3,5	630.0104	180	7	640.0215	-	15
605.0115	140	7	620.1302	60	3,5	630.0301	60	12	640.0217	-	17
605.0116	150	13	620.1303	120	6	630.0302	60	12	640.0220	-	20
615.0001	30	12	620.1304	120	6	630.0901	90	5	640.0230	-	30
615.0002	60	12	620.1305	150	8	630.0902	90	5	640.0250	-	50
615.0003	60	12	620.1306	150	8	630.0903	150	6,5	640.0310	-	10
615.0004	70	15	620.1701	80	4,5	630.0904	150	6,5	640.0315	-	15
620.0101	80	4,5	620.1702	80	4,5	630.1101	90	5	640.0317	-	17
620.0102	80	4,5	620.1703	150	6,5	630.1102	90	5	640.0320	-	20
620.0103	150	6,5	620.1704	150	6,5	630.1103	150	6,5	640.0330	-	30
620.0104	150	6,5	620.1705	320	11	630.1104	150	6,5	640.0350	-	50
620.0105	320	11	620.1706	320	11	630.1701	90	5,5	640.2315	-	15
620.0106	320	11	620.1901	60	12	630.1702	90	5,5	640.2317	-	17
			620.1902	60	12	630.1703	180	7	640.2415	-	15
			620.1903	60	12	630.1704	180	7	640.2417	-	17
			620.1904	60	12	630.1901	60	12	640.2420	-	20
			620.3001	50	3,5	630.1902	60	12	640.2430	-	30
			620.3002	60	4	630.2301	400	15	640.2450	-	50
			620.3101	18	1	630.3001	60	4	660.0601	30	-

DRIVE TORQUES AND MAXIMUM TENSILE FORCE

(1 t = 1 Mp = 10 KN)

	max. Torque Nm	max. t		max. Torque Nm	max. t		max. Torque Nm	max. t		max. Torque Nm	max. t
660.0602	60	-	670.0131	200	10	700.1185	30	2	700.1713	250	4,3
660.0603	60	-	670.0141	-	10	700.1190	30	1,2	700.1740	-	20
660.0605	100	-	670.0151	-	10	700.1191	15	1	700.1750	60	10
670.0013	280	14	670.0161	200	20	700.1192	20	1,5	700.1755	300	-
670.0014	280	14	670.0171	30	20	700.1193	15	1	700.1757	300	-
670.0015	280	14	670.0181	-	20	700.1200	60	10	700.1790	-	20
670.0021	70	3,5	670.0201	30	2,5	700.1240	40	2,5	700.1791	-	20
670.0031	70	3,5	670.0221	60	-	700.1260	35	1,2	700.1796	300	16
670.0041	60	1,8	670.0231	120	-	700.1300	70	4	700.5610	40	3
670.0051	60	1,8	670.0232	120	-	700.1400	60/400	10	700.5615	40	3
670.0060	80	4	670.0233	120	-	700.1400-1	60	10	700.5620	40	2,5
670.0061	60	4	670.0241	120	-	700.1400-5	400	-	700.5625	40	2,5
670.0062	60	4	700.1100	35/50	-	700.1405	400	-	700.5630	70	3,5
670.0063	80	4	700.1120	18	1,2	700.1410	60	10			
670.0101	50	-	700.1130	30	1,2	700.1415	-	11			
670.0102	120	-	700.1150	45	-	700.1420	-	11			
670.0103	160	-	700.1160	80	-	700.1470	-	11			
670.0104	280	-	700.1170	80	-	700.1500	15	1,5			
670.0105	400	-	700.1180	80	-	700.1650	20	1,5			
670.0106	280	-	700.1181	10	-	700.1700	250	4,3			
670.0111	70	3,5	700.1182	40	-	700.1710	60	1			
670.0121	40	3,5	700.1183	60	-	700.1711	100	1,9			
670.0122	40	3,5	700.1184	80	-	700.1712	180	3,2			

Handling puller spindles

The overloading of a spindle is under no circumstances dependent on the number of applications and should therefore be avoided by a considered approach in the selection (e.g. dimension) or use.

The foundation for a long working life will already be laid at the time of first use. If work is done here without the lubrication required, it leads quickly to overheating and thus to spindle wear, which naturally has an abrupt negative influence on the working life.

To avoid this:

- Excessive heating, e.g. with a welding torch leads to structural alterations in the spindle material, which will adversely influence characteristics such as breakage resistance and stretchability.
- Ensure that the spindle is precisely positioned in the pulling axis to prevent the spindle suffering from bending stress.
- Introduce work breaks in order to avoid excessive overheating of the spindle, traverse thread or nut.
- Under no circumstances may spindles be operated with electrical or impact wrenches.

Maintenance and care:

- regular cleaning of the spindle with cleaner's solvent, brake cleaner, part-cleaning solution etc.
- After cleaning, lubricate spindle with machine oil
- For conditions of extreme stress the use of a high-performance lubricant is recommended on the stressed spindle parts
- suitable lubricants: See below for high-performance fitting lubricant
- Check spindles regularly for bending by rolling them on a plane surface
- spindles showing significant bending should be replaced

Special thread compound

This special compound is an outstanding lubricant for static highly-stressed components such as, for example, thread spindles. Influence factors, e.g. moisture or friction, lead as a rule to increased wear and jamming. Thanks to its special composition and the solids it contains the surface roughness of the surface to be protected is completely filled in. In this way a fully enclosed surface is formed, which significantly reduces friction and offers an effective protection from corrosion.

This increases the working life of the thread spindles substantially and ensures problem-free functioning even at intense heating of up to max. 1200°C.



Description		
980.1085	Special thread grease, gun	22
980.1090	Special thread grease, tube	5

BASIC PULLER VARIANTS AND AREAS OF APPLICATION

External pulling

Pulling component of a shaft or axle
 e.g.: Ball bearing, tapered roller bearing, gear wheels, belt pulleys, etc.

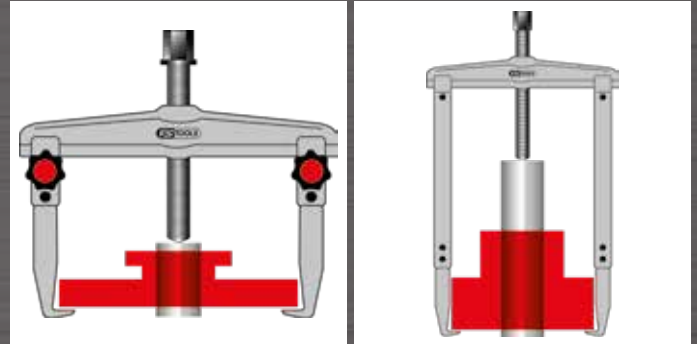

Internal pulling

Component is in a housing (hole)
 e.g.: Ball bearing, needle bearing, outer bearing ring, bushes, sleeves, etc.

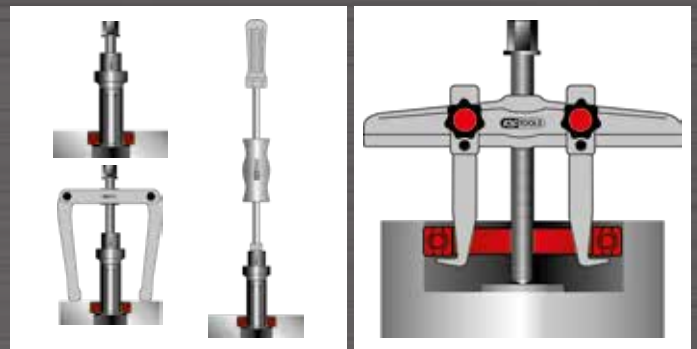

Extraction and pulling from housings

Component is in the housing and on a shaft or axle
 e.g.: Ball-bearing

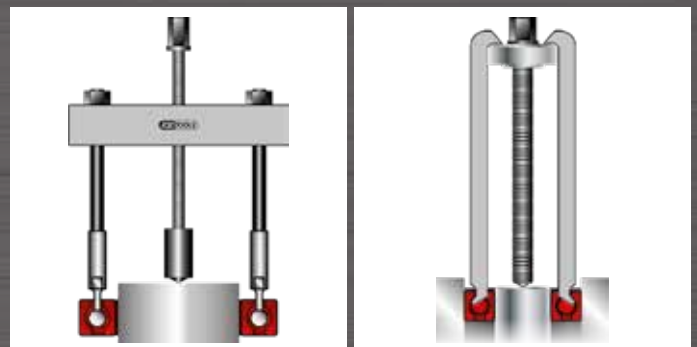

Separator puller

Pull component from a shaft or axle - back is tight or flush on e.g.: Ball bearing, roller bearing, gear wheels, bushes, sleeves, etc.

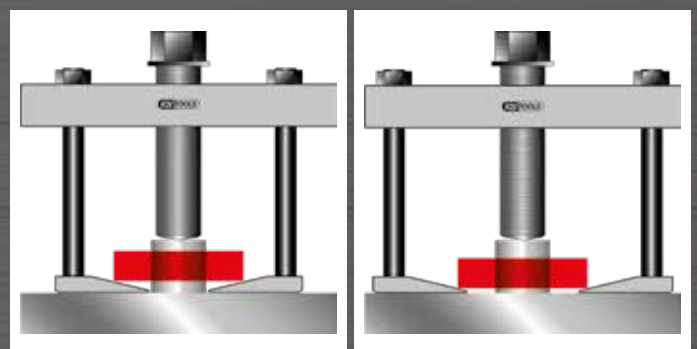

SPECIAL PULLER

Ball bearing extractor

Application areas:

These special pullers are always used when the ball bearing sits on a shaft and at the same time in a housing and cannot be gripped through the hole either from outside or from inside. Thanks to the slim design lower-lying bearings can also be extracted or pulled.

Ball bearing extractor (hemisphere)

Work steps:

- 1.) Drill bearing cage at two opposite points in each case between two balls
- 2.) Bend cage plate and create space for the hemisphere adapter
- 3.) Position puller with the spindle on the shaft spigot
- 4.) Place appropriate hemisphere into the bearing (ball groove) and turn by 90°
- 5.) By activating the spindle bring the hooks to the pull and extract bearing.

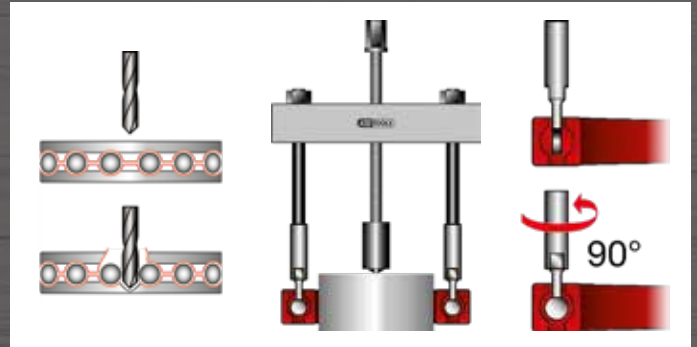

Ball bearing extractor (claws)

Work steps:

- 1.) Determine the number of ball bearings to be pulled
- 2.) Using the application table (see below) select the right puller with the appropriate claws.
 Tip: If the number of ball bearings to be pulled cannot be defined, the distance between the outer and inner bearing ring is to be measured. When this measurement is rounded to the nearest millimetre, the result is usually the shaft strength of the hook required.
- 3.) Place the hooks as symmetrically as possible after one another with the claws between the balls in the external bearing ring.
- 4.) Position spindle on the shaft spigot of the shaft end and hang hooks on the traverse.
- 5.) By activating the spindle bring the hooks to the pull and extract bearing.

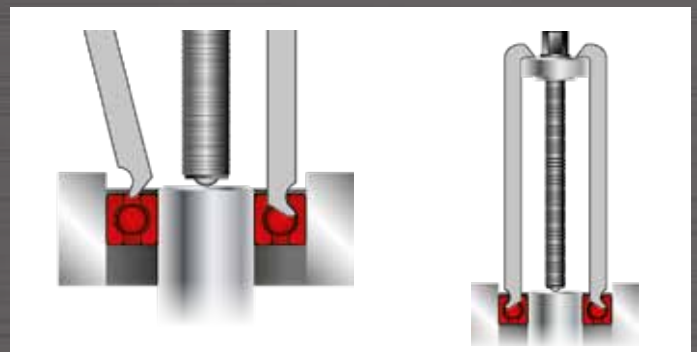

Application table for 650.0010

Extractor no.	Hook set no.	for ISO ball bearing no.			
650.0011	655.0011	6000	6200		
		6001			
		6002			
		6003			
	655.0012	6004	6201		
650.0012	655.0013	6006	6203	6300	
	655.0014	6007	6204	6301	
		6008	6205	6302	
	655.0015			6303	
650.0013	655.0014			6304	

Extractor no.	Hook set no.	for ISO ball bearing no.				
650.0013	655.0015		6206			
	655.0016		6207	6305		
650.0014	655.0015	6009				
	655.0017		6208	6306		
650.0015	655.0015	6010				
	655.0016	6011				
		6012				
	655.0018		6209	6307	6403	
			6210	6308*	6404*	
			6211*	6309*	6405*	
			6212*	6310*	6406*	
					6410*	

Ball bearing nos. with (*) are held and pulled with the spacer plates screwed on to the hook base (655.0018). Using 12 screwed-on, folding spacer plates each, the distance between the inner bearing ring and hook base is variably balanced out. Unlisted bearings or special sizes are available on demand.

PRECISION INTERNAL EXTRACTOR



Strut adapter

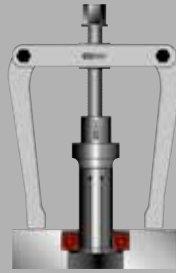

Strut adapter with bridge



Strut adapter with hammer

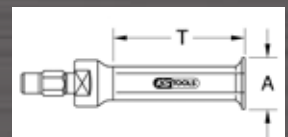
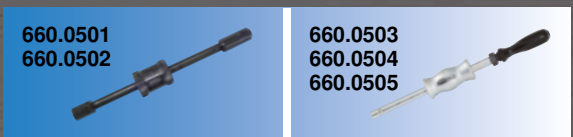

Item	Ø A mm min. - max.	T mm	Internal extractors need as removing tool suitable				Adaptor thread C	SW1 mm	SW2 mm	max. torque with double ended support		
			double ended support		slide hammer					max Nm	Double ended support	
660.0101	5-7	30	660.0601		660.0501		M10	10	13	3	660.0601	
660.0102	6-8	30						M10	10	13	3	660.0601
660.0103	7-9	30						M10	10	13	7	660.0601
660.0104	8-10	30						M10	10	13	7	660.0601
660.0105	9-12	30						M10	10	13	12	660.0601
660.0106	10-13	30						M10	10	13	15	660.0601
660.0107	12-15	30						M10	10	13	15	660.0601
660.0108	13-17	50						M10	10	13	24	660.0601
660.0109	14-19	60						M10	10	13	28	660.0601
660.0111	15-20	60						M10	10	13	28	660.0601
660.0112	16-21	60						M10	10	13	32	660.0601
660.0113	18-23	60						M10	10	17	40	660.0601
660.0114	20-25	60						M10	10	17	40	660.0601
660.0115	22-27	60						M10	10	17	40	660.0601
660.0116	25-30	60				M10	10	17	40	660.0601		
660.0117	25-40	45				M10	13	19	45	660.0601		
660.0118	28-35	60				M10	10	17	45	660.0601		
660.0119	30-37	70				M10	17	22	45	660.0601		
660.0121	35-42	70				M10	17	22	45	660.0601		
660.0122	38-45	70				M10	17	22	45	660.0601		
660.0123	40-47	70				M10	17	22	45	660.0601		
660.0124	43-50	70				M10	17	22	45	660.0601		
660.0125	40-75	100	660.0603				G 3/8"	17	27	45	660.0602	
660.0126	45-55	100		660.0604			G 3/8"	19	27	45	660.0602	
660.0127	50-60	100		660.0605			G 3/8"	19	27	45	660.0602	
660.0128	70-115	100					G 3/8"	19	27	45	660.0602	

STRUCTURE OF A PULLER

Quick-clamp device

- The quick-clamping device enables tool-free and secure clamping of the arms by hand
- to move - loosen the knurled thumb screws

Hook with stepping

- Hooks can be moved by loosening the upper quick-clamping device

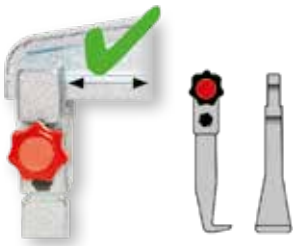

Standard hook without stepping

- Movement of the hooks by loosening the upper fast-action nut not possible. Here the fast-action nuts and lower nuts need to be loosened.

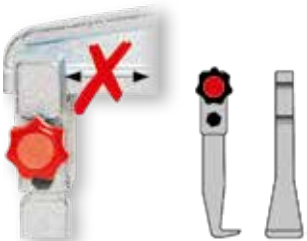

Traverse

- Traverse formed from quenched and tempered steel
- precision-milled guides
- designed for the highest stress

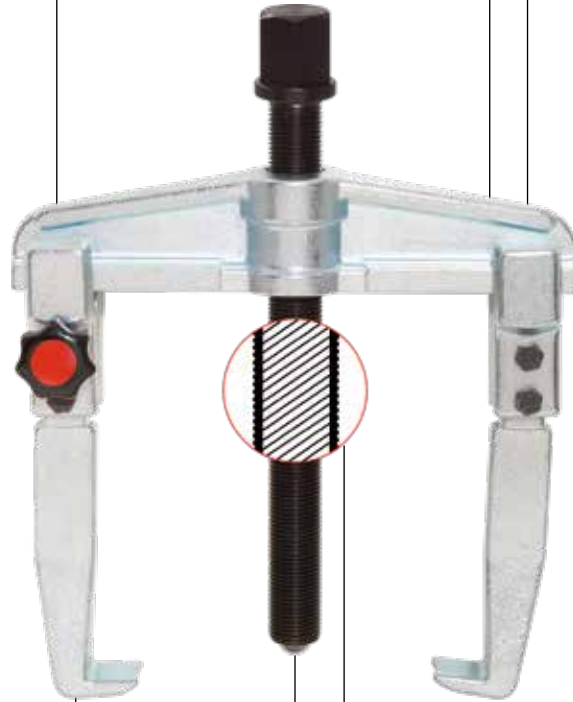

Two-screw quick-clamp device

- Using the fixing screws the hooks are braced securely on the traverse. The lower screw forms a positive connection of the adjustable block with the hooks. The upper screw clamps the adjustable block on the traverse.

Hook with stepping

- Hooks can be moved by loosening the upper nut

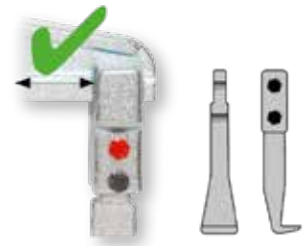

Standard hook without stepping

- Movement of the hooks by loosening the upper fast-action nut not possible. Here both nuts must be loosened.

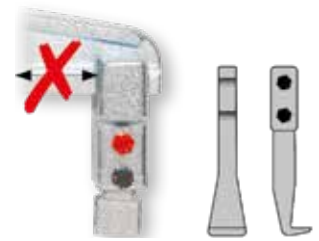

Universal hooks

- Formed from quenched and tempered steel and functional surfaces are precision-milled
- positive and force-closed connection between traverse hooks

Spindle

- Turned from quenched and tempered steel
- the thread is rolled and thus has a high stability and precision
- especially wear-resistant, case-hardened spindles, from G1/2" all spindles inductively hardened
- Hex drive with anti-slip device (collar)

Different pressure peaks

Differences after few work cycles

Spindle with ball



- No wear recognisable
- central pressing of the spindle continues to be guaranteed

Spindle with live centre



- Jamming in the spindle body
- Deformation of the dead centre
- Pressing the spindle centrally is no longer possible
- Replacement of the spindle required

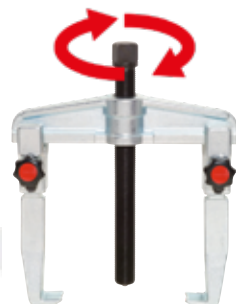

HYDRAULIC SPINDLES WITH MECHANICAL DRIVE

Advantages

- low force
- compact form with very high compressive force
- spindle-saving straight-line motion - min. friction at the pressure peaks
- Prevention of turning movement especially with rotating parts
- minimum application of force 60- 70 Nm at maximum output of up to 15t/150KN

Hydraulic press

- Draw-off strength 8t/80KN or 15t/150KN
- short stroke of 8 or 12 mm
- can be used in conjunction with all mechanical pullers
- used between shaft end and puller spindle
- the use saves the thread of the original puller spindle

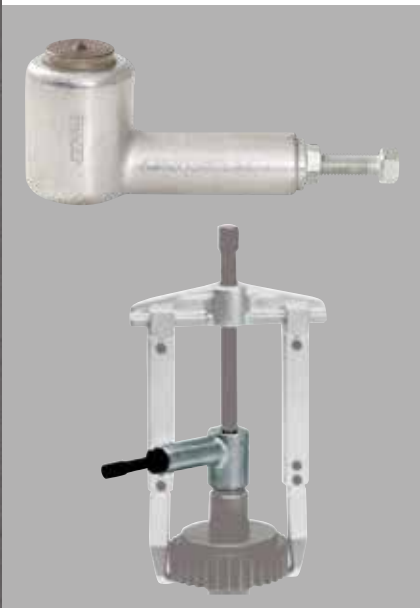

Grease hydraulic spindle short

- Draw-off strength 10t/100KN / 12t/120KN
- short stroke 10 mm
- use in the module system and special pullers with UN support 1-1/2"x16 thread
- pre-tensioning and positioning via the external thread on the cylinder
- the hydraulics are activated with a tommy bar or hex drive of the pressure spindle
- 12t spindle with safety pin



Grease hydraulic spindle long

- lean form - draw-off strength 12t/120KN or 15t/150KN
- short stroke 12 mm
- use in standard and special pullers with G support 1/2"x14 thread / G 3/4"x14 thread and G 1"x11 thread
- pre-tensioning and positioning via the external thread of the large spindle
- the hydraulics are activated using the small pressure spindle



Guide on switching to a grease hydraulic spindle long

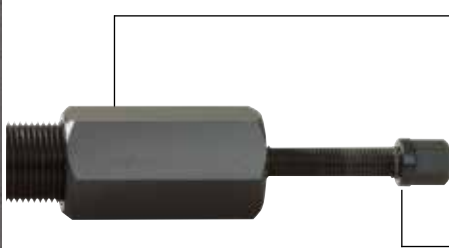

- Loosen stud
- screw off whole cap (SW large)
- screw spindle body into puller
- screw cap back on up to limit stop
- place stud on again and secure by tightening

Working method:

- place on puller
- pre-tension mechanically with large width across flats
- secure puller position sichern
- screw pressure spindle into the press

Caution: Power wrench prohibited

- If the piston stroke is not sufficient for loosening, the work step must be repeated. Turn pressure spindle back, pre-tension again mechanically and screw pressure spindle in again

Safety note:

- Tighten all screw connections before pulling, as otherwise there is a danger of slipping

OIL HYDRAULICS



Advantages

- highest-performance drive form for the use of 10t/100KN up to max. 50t/100KN
- as screw-in / spindle / flat-topped and trunk piston cylinder
- hydraulic pumps optionally as manual / pneumatic or electrical variant
- hydraulic units work very conveniently and with low application of force
- the advantages lie in the long work path (stroke) of the pistons and the extremely high pressure force

Combination options oil hydraulics with puller

Spindle hydraulics cylinder

Flat hydraulics cylinder

Screw-in hydraulics cylinder

Trunk piston hydraulics cylinder

	Spindle hydraulics cylinder		Flat hydraulics cylinder		Screw-in hydraulics cylinder		Trunk piston hydraulics cylinder				
Hydraulic cylinder	640.0130		640.0140	640.0150	640.0110	640.0120		640.0170	640.0180	640.0190	
Mounting thread	G1" x 11g		2xThread M6 Depth gauge 36,6	2xbore M10 Depth gauge 36,6	UNC 2.1/4"x14	M68x2		UNC 1" -8	UNC 1.1/4" -7	UNS 1.5/8"-5.1/2"	
Max. Power	17t / 170KN		10t / 100KN	20t / 200KN	10t / 100KN	15t / 150KN		20t / 200KN	30t / 300KN	50t / 500KN	
		Arms/Mod.					Arms/Mod.				Arms/Mod.
Use with puller	620.0108 640.0217 640.0317 640.2317 640.2417	2 B 2 B 3 L 3 BRS 3 LRS	670.0151 670.0181	670.0181	640.0210 640.0310	640.0215 640.0315 640.2315 640.2415	2 B 3 L 3 BRS 3 LRS	640.0220 640.0320 640.2420	640.0230 640.0330 640.2430	640.0250 640.0350 640.2450	2 L 3 L 3 LRS
Use with traverse	645.0217 645.0317 645.2317 645.2417	3 L 3 BRS 3 LRS			645.0210 645.0310	645.0215 645.0315 645.2315 645.2415	3 L 3 BRS 3 LRS	645.0220 645.0320 645.2420	645.0230 645.0330 645.2430	645.0250 645.0350 645.2450	3 L 3 LRS

KS Standard hydraulics coupling appropriate for typical systems in the market such as Celette, Enerpac, Sun etc.

All oil hydraulics cylinders can be combined or operated with the following pumps:

Loose half - tube side



Fixed half - cylinder side



640.0010



640.0020



640.0030



B = Standard/ bar puller

L = side plate puller

BRS = Standard/ bar puller
with radially swivelling arms

LRS = side plate puller
with radially swivelling arms



COMBINATION OPTIONS FOR STANDARD / BAR PULLER

Mechanical spindle

Hydraulic spindle

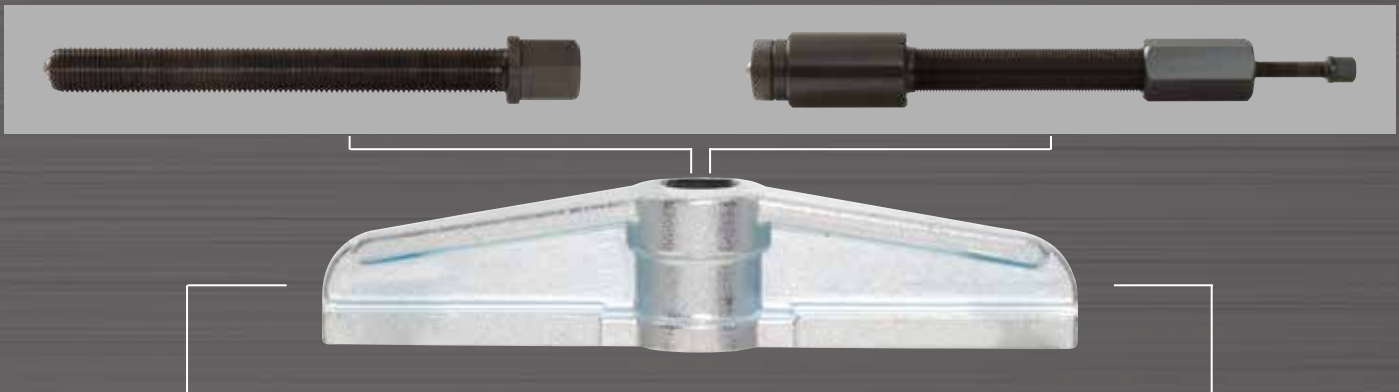

Hooks with quick-clamping device

Hooks with two-screw clamping device



Quick-clamping hooks	
Hook No.	for Puller
615.1001	620.1101 / 620.1102 630.1101 / 630.1102
615.1002	620.1101 / 620.1102 630.1101 / 630.1102
615.1003	620.1101 / 620.1102 630.1101 / 630.1102
615.1004	620.1101 / 620.1102 630.1101 / 630.1102
615.1005	620.1101 / 620.1102 630.1101 / 630.1102
615.1006	620.1101 / 620.1102 630.1101 / 630.1102
615.1007	620.1103 / 620.1104 630.1103 / 630.1104
615.1008	620.1103 / 620.1104 630.1103 / 630.1104
615.1009	620.1103 / 620.1104 630.1103 / 630.1104
615.1101	620.1701 / 620.1702 630.1701 / 630.1702
615.1102	620.1703 / 620.1704 630.1703 / 630.1704
615.1103	620.1705 / 620.1706 630.1903 / 630.1904

Two-screw clamp hooks					
Hook No.	for Puller	Hook No.	for Puller	Hook No.	for Puller
615.0101	620.0101 / 620.0102 630.0101 / 630.0102	615.0503	620.0105 / 620.0106 620.0107 620.0505 / 620.0506 620.0507 620.0703 / 620.0704 620.0705	615.0508	620.0108 630.2301 640.0210 / 640.0215 640.0217 640.2315 / 640.2317
615.0103	620.0105 / 620.0106 620.0107 620.0303 / 620.0304 620.0305 / 620.0306	615.0505	620.0105 / 620.0106 620.0107 620.0511 / 620.0512 620.0513 620.0709 / 620.0710 620.0711	615.0902	620.0901 / 620.0902 630.0901 / 630.0902
615.0501	620.0101 / 620.0102 620.0103 / 620.0104 620.0301 / 620.0302 620.0501 / 620.0502 630.0101 / 630.0102 630.0103 / 630.0104 630.0301 / 630.0302	615.0507	620.0108 630.2301 640.0210 / 640.0215 640.0217 640.2315 / 640.2317	615.0904	620.0103 / 620.0104 620.0903 / 620.0904 630.0903 / 630.0904
615.0501	620.0101 / 620.0102 620.0103 / 620.0104 620.0301 / 620.0302 620.0501 / 620.0502 630.0101 / 630.0102 630.0103 / 630.0104 630.0301 / 630.0302	615.0506	620.0108 630.2301 640.0210 / 640.0215 640.0217 640.2315 / 640.2317	615.0906	620.0103 / 620.0104 620.0903 / 620.0904 630.0903 / 630.0904
615.0502	620.0103 / 620.0104 620.0503 / 620.0504 620.0701 / 620.0702 630.0103 / 630.0104 630.0301 / 630.0302	615.0507	620.0108 630.2301 640.0210 / 640.0215 640.0217 640.2315 / 640.2317	615.0908	620.0101 / 620.0102 620.0901 / 620.0902 630.0901 / 630.0902

Caution: The hooks marked in red are not the original hooks relating to the pullers indicated, but can be used in these.

INTERNAL EXTRACTORS

Precision internal extractor

- Centering shaft
- For the removal of secure bearings and bushes
- Special tool steel



	A mm	mm	mm	T mm	max N·m	kg	€	
660.0101	5-7	M10	10	13	30,0	3	47,50	
660.0102	6-8	M10	10	13	30,0	3	47,50	
660.0103	7-9	M10	10	13	30,0	7	47,50	
660.0104	8-10	M10	10	13	30,0	7	47,50	
660.0105	9-12	M10	10	13	30,0	12	47,50	
660.0106	10-13	M10	10	13	30,0	15	47,50	
660.0107	12-15	M10	10	13	30,0	15	38,50	
660.0108	13-17	M10	10	13	50,0	24	70	38,50
660.0109	14-19	M10	10	13	60,0	28	90	39,50
660.0111	15-20	M10	10	13	60,0	28	90	39,50
660.0112	16-21	M10	10	13	60,0	32	90	39,50
660.0113	18-23	M10	10	17	60,0	40	110	50,50
660.0114	20-25	M10	10	17	60,0	40	110	52,50
660.0115	22-27	M10	10	17	60,0	40	110	52,50
660.0116	25-30	M10	10	17	60,0	40	120	53,50
660.0117	25-40	M10	13	19	45,0	45	260	69,50
660.0118	28-35	M10	10	17	60,0	45	280	55,90
660.0119	30-37	M10	17	22	70,0	45	280	63,50
660.0121	35-42	M10	17	22	70,0	45	280	73,90
660.0122	38-45	M10	17	22	70,0	45	290	73,90
660.0123	40-47	M10	17	22	70,0	45	300	73,90
660.0124	43-50	M10	17	22	70,0	45	310	80,50
660.0125	40-75	G 3/8"	17	27	100,0	45	760	119,90
660.0126	45-55	G 3/8"	19	27	100,0	45	650	95,50
660.0127	50-60	G 3/8"	19	27	100,0	45	680	115,50
660.0128	70-115	G 3/8"	19	27	130,0	45	1400	177,90

Double ended support for internal extractor

- Extremely robust spindle with inductively hardened thread
- Special tool steel



	A mm	max N·m	mm	Internal extractors	mm	kg	€
660.0601	35-75	30	12	M10	M16x1,5 x 136	0,70	44,90
660.0602	60-130	60	19	M10xG3/8"	M24x1,5 x 160	1,60	67,50
660.0603	60-130	60	19	G3/8"	M24x1,5 x 160	1,50	67,50
660.0605	55-205	100	22	G3/8"	G1/2"x14g x 210	3,80	151,90

Slide hammer

- Flexible removal tool
- Internal thread for holding various pullers, bolts and hooks
- Ideal for removing ball bearings, wheel hubs etc.
- Ideal for limited access areas
- Special tool steel



	L1 mm	L2 mm	D1 mm	D2 mm	mm	kg	€
660.0501	170	40,0	10,0	30,0	M10	0,40	32,50
660.0502	170	80,0	10,0	50,0	M10	0,90	46,50
660.0503	250	100,0	16,0	45,0	M10	1,30	67,50
660.0504	250	100,0	16,0	45,0	M10+G3/8"	1,40	75,90
660.0505	250	100,0	16,0	60,0	G3/8"	2,60	108,50

INTERNAL EXTRACTORS SETS

Precision internal extractor set ø 10,0 - 37,0 mm

- Centering shaft
- For the removal of secure bearings and bushes
- Extremely robust spindle with inductively hardened thread
- Special tool steel
- In durable plastic storage case
- For pulling/hitting the pilot bearing



	kg	€		
660.0014	7 pcs	Precision internal extractor set ø 10,0 - 37,0 mm	2,42	318,90

consists of:

	kg	
660.0106	Precision internal extractor, 10-13mm	50
660.0109	Precision internal extractor, 14-19mm	90
660.0114	Precision internal extractor, 20-25mm	110
660.0116	Precision internal extractor, 25-30mm	120
660.0119	Precision internal extractor, 30-37mm	280
660.0601	Double ended support for internal extractor, 35-75mm	700
660.0501	Slide hammer, 170mm, M10, variante1	400



Precision internal extractor set ø 10,0 - 45,0 mm

- Centering shaft
- For the removal of secure bearings and bushes
- Extremely robust spindle with inductively hardened thread
- Special tool steel
- In durable plastic storage case



	kg	€		
660.0011	7 pcs	Precision internal extractor set ø 10,0 - 45,0 mm	2,36	436,50

consists of:

	kg	
660.0106	Precision internal extractor, 10-13mm	50
660.0109	Precision internal extractor, 14-19mm	90
660.0114	Precision internal extractor, 20-25mm	110
660.0116	Precision internal extractor, 25-30mm	120
660.0119	Precision internal extractor, 30-37mm	280
660.0122	Precision internal extractor, 38-45mm	290
660.0601	Double ended support for internal extractor, 35-75mm	700

Precision internal extractor set ø 10,0 - 75,0 mm

- Centering shaft
- For the removal of secure bearings and bushes
- Extremely robust spindle with inductively hardened thread
- Special tool steel
- In durable plastic storage case



	kg	€		
660.0012	9 pcs	Precision internal extractor set ø 10,0 - 75,0 mm	4,92	647,50

consists of:

	kg	
660.0106	Precision internal extractor, 10-13mm	50
660.0109	Precision internal extractor, 14-19mm	90
660.0114	Precision internal extractor, 20-25mm	110
660.0116	Precision internal extractor, 25-30mm	120
660.0119	Precision internal extractor, 30-37mm	280
660.0122	Precision internal extractor, 38-45mm	290
660.0125	Precision internal extractor, 40-75mm	760
660.0601	Double ended support for internal extractor, 35-75mm	700
660.0602	Double ended support for internal extractor, 60-130mm, M10xG3/8"	1600

Precision internal extractor set ϕ 15,0 - 75,0 mm

- Centering shaft
- For the removal of secure bearings and bushes
- Extremely robust spindle with inductively hardened thread
- Special tool steel
- In durable plastic storage case



	kg	€
660.0015 5 pcs Precision internal extractor set ϕ 15,0 - 75,0 mm	3,60	368,50

consists of:

	kg	€
660.0111 Precision internal extractor, 15-20mm	90	
660.0114 Precision internal extractor, 20-25mm	110	
660.0117 Precision internal extractor, 25-40mm	260	
660.0125 Precision internal extractor, 40-75mm	760	
660.0602 Double ended support for internal extractor, 60-130mm, M10xG3/8"	1600	

Precision internal extractor set ϕ 10,0 - 115,0 mm

- Centering shaft
- For the removal of secure bearings and bushes
- Extremely robust spindle with inductively hardened thread
- Special tool steel
- In durable plastic storage case



	kg	€
660.0013 10 pcs Precision internal extractor set ϕ 10,0 - 115,0 mm	9,72	1053,90

consists of:

	kg	€
660.0106 Precision internal extractor, 10-13mm	50	
660.0109 Precision internal extractor, 14-19mm	90	
660.0114 Precision internal extractor, 20-25mm	110	
660.0116 Precision internal extractor, 25-30mm	120	
660.0119 Precision internal extractor, 30-37mm	280	
660.0122 Precision internal extractor, 38-45mm	290	
660.0125 Precision internal extractor, 40-75mm	760	
660.0601 Double ended support for internal extractor, 35-75mm	700	
660.0128 Precision internal extractor, 70-115mm	1400	
660.0605 Double ended support for internal extractor, 55-205mm	3800	

INTERNAL EXTRACTORS & PULLER SETS

Precision internal extractor and puller set 10 - 45 mm

- Through reversing the arms internal and external applications are possible
- Wide range of arms and hydraulic spindles available
- Centering shaft
- For the removal of secure bearings and bushes
- Extremely robust spindle with inductively hardened thread
- Special tool steel
- In durable plastic storage case



	kg	€
660.0022 10 pcs Precision internal extractor and puller set 10 - 45 mm	5,58	756,50

consists of:

	kg	€
660.0106 Precision internal extractor, 10-13mm	50	
660.0109 Precision internal extractor, 14-19mm	90	
660.0114 Precision internal extractor, 20-25mm	110	
660.0116 Precision internal extractor, 25-30mm	120	
660.0119 Precision internal extractor, 30-37mm	280	
660.0122 Precision internal extractor, 38-45mm	290	
660.0601 Double ended support for internal extractor, 35-75mm	700	
620.0101 Universal 2 arm puller, 20-90mm, legs 100mm	1000	
620.3101 Pole clamp 2-jaw puller, 10-60mm	160	
670.0221 Draw off lining, ϕ 5-32mm	1400	

Precision internal extractor and puller set 10 - 75 mm

- Through reversing the arms internal and external applications are possible
- Wide range of arms and hydraulic spindles available
- Centering shaft
- For the removal of secure bearings and bushes
- Extremely robust spindle with inductively hardened thread
- Special tool steel
- In durable plastic storage case



	kg	€
660.0023 13 pcs Precision internal extractor and puller set 10 - 75 mm	11,60	1114,90

consists of:

	kg	€
660.0106 Precision internal extractor, 10-13mm	50	
660.0109 Precision internal extractor, 14-19mm	90	
660.0114 Precision internal extractor, 20-25mm	110	
660.0116 Precision internal extractor, 25-30mm	120	
660.0119 Precision internal extractor, 30-37mm	280	
660.0122 Precision internal extractor, 38-45mm	290	
660.0125 Precision internal extractor, 40-75mm	760	
660.0601 Double ended support for internal extractor, 35-75mm	700	
660.0603 Double ended support for internal extractor, 60-130mm, G3/8"	1500	
620.0101 Universal 2 arm puller, 20-90mm, legs 100mm	1000	
620.0103 Universal 2 arm puller, 50-160mm, legs 150mm	3000	
620.3101 Pole clamp 2-jaw puller, 10-60mm	160	
670.0221 Draw off lining, ϕ 5-32mm	1400	

Precision internal extractor and puller set 10 - 115 mm

- Through reversing the arms internal and external applications are possible
- Wide range of arms and hydraulic spindles available
- Centering shaft
- For the removal of secure bearings and bushes
- Extremely robust spindle with inductively hardened thread
- Special tool steel
- In durable plastic storage case



	kg	€
660.0021 14 pcs Precision internal extractor and puller set 10 - 115 mm	15,63	1512,90

consists of:

	kg	€
660.0106 Precision internal extractor, 10-13mm	50	
660.0109 Precision internal extractor, 14-19mm	90	
660.0114 Precision internal extractor, 20-25mm	110	
660.0116 Precision internal extractor, 25-30mm	120	
660.0119 Precision internal extractor, 30-37mm	280	
660.0122 Precision internal extractor, 38-45mm	290	
660.0125 Precision internal extractor, 40-75mm	760	
660.0128 Precision internal extractor, 70-115mm	1400	
660.0601 Double ended support for internal extractor, 35-75mm	700	
660.0605 Double ended support for internal extractor, 55-205mm	3800	
620.0101 Universal 2 arm puller, 20-90mm, legs 100mm	1000	
620.0103 Universal 2 arm puller, 50-160mm, legs 150mm	3000	
620.3101 Pole clamp 2-jaw puller, 10-60mm	160	
670.0221 Draw off lining, ϕ 5-32mm	1400	



BALL BEARING EXTRACTORS

Universal ball bearing extractor set

- Less risk of slippage due to automatically closing pulling arm
- 13 puller variants possible
- Extremely robust spindle with inductively hardened thread
- Excellent power transfer
- Special tool steel
- In durable steel storage case



				€
650.010	37 pcs	Universal ball bearing extractor set	8,00	959,90

consists of:

650.0011	Ball bearing extractor without legs, 26mm	300
650.0012	Ball bearing extractor without legs, 34mm	400
650.0013	Ball bearing extractor without legs, 41mm	500
650.0014	Ball bearing extractor without legs, 49mm	900
650.0015	Ball bearing extractor without legs, 63mm	1200
655.0011	Adaptor legs for ball bearing extractor, 4 pcs ISO 6000	100
655.0012	Adaptor legs for ball bearing extractor, 4 pcs ISO 6004	100
655.0013	Adaptor legs for ball bearing extractor, 4 pcs ISO 6006	200
655.0014	Adaptor legs for ball bearing extractor, 4 pcs ISO 6007	200
655.0015	Adaptor legs for ball bearing extractor, 4 pcs ISO 6009	300
655.0016	Adaptor legs for ball bearing extractor, 4 pcs ISO 6011	400
655.0017	Adaptor legs for ball bearing extractor, 4 pcs ISO 6208	600
655.0018	Adaptor legs for ball bearing extractor, 4 pcs ISO 6209	800

Ball bearing extractor without legs

- Consists of adaptor and spindle
- For ball bearings in waves or housings
- Extremely robust spindle with inductively hardened thread
- Special tool steel



	Ø mm	mm	mm		€
650.0011	26	M10 x 150	12	0,30	33,50
650.0012	34	M12 x 199	14	0,40	43,90
650.0013	41	M14x1,5 x 200	17	0,50	44,90
650.0014	49	M18x1,5 x 240	19	0,90	48,50
650.0015	63	G1/2"x14g x 230	22	1,20	62,50

Adaptor legs for ball bearing extractor, 4 pcs

- Can be used with adaptor legs and spindles available separately
- For ball bearings in waves or housings
- Special tool steel



	L mm	Substrate for ISO bearing		€
655.0011	120	6000, 6001, 6002, 6003, 6200	100	54,50
655.0012	120	6004, 6005, 6201, 6202	100	55,90
655.0013	130	6006, 6203, 6300	200	66,50
655.0014	130	6007, 6008, 6204, 6205, 6301, 6302	200	66,50
655.0015	150	6009, 6010, 6206, 6303, 6304	300	66,50
655.0016	150	6011, 6012, 6207, 6305	400	69,50
655.0017	190	6208, 6306	600	86,90
655.0018	190	6209- 6212, 6307- 6310, 6403- 6406, 6410	800	147,90

Universal ball bearing puller set

- For simple and fast removing of ball bearings without removal of the shaft
- Pulling power influences uniformly on the interior and outside ring
- Special tool steel
- In durable plastic storage case
- Suited for ISO bearings: 6004-6010, 6201-6206, 6300-6304

Ideal for use in SKF, FAG, Timken, NTN bearings etc.
Adaptor diameter: 5.5 - 6 - 8 mm



				€
700.1500	21 pcs	Universal ball bearing puller set	0,82	101,90

consists of:

700.1501	Extension set long, 2 pcs, for 700.1500	110
700.1502	Centre point, for 700.1500	30
700.1503	Tie rod set, 2 pcs, for 700.1500	60
700.1504	Ball head bearing adaptor set, 2 pcs, Ø 5.5 mm	24
700.1505	Ball head bearing adaptor set, 2 pcs, Ø 6.0 mm	24
700.1506	Ball head bearing adaptor set, 2 pcs, Ø 8.0 mm	26
700.1507	Extension set short, 2 pcs, for 700.1500	30
700.1508	U disc for tie rod, pack of 4, for 700.1500	10
700.1509	Spindle, for 700.1500	164
700.1510	Traverse, for 700.1500	202
700.1511	Nut set for tie rod, 2 pcs, for 700.1500	10

Universal ball bearing puller set

- For simple and fast removing of ball bearings without removal of the shaft
- Pulling power influences uniformly on the interior and outside ring
- Special tool steel
- In durable plastic storage case
- Suited for ISO bearings: 6207-6211, 6205-6208, 6303-6305

Ideal for use in SKF, FAG, Timken, NTN bearings etc.
Adaptor diameter: 11 - 12.5 - 15 mm



				€
700.1600	21 pcs	Universal ball bearing puller set	1,69	178,90

consists of:

700.1601	Extension set long, 2 pcs, for 700.1600	204
700.1602	Centre point, for 700.1600	50
700.1603	Tie rod set, 2 pcs, for 700.1600	178
700.1604	Ball head bearing adaptor set, 2 pcs, Ø 11.0 mm	88
700.1605	Ball head bearing adaptor set, 2 pcs, Ø 12.5 mm	96
700.1606	Ball head bearing adaptor set, 2 pcs, Ø 15.0 mm	110
700.1607	Extension set short, 2 pcs, for 700.1600	88
700.1608	U disc for tie rod, pack of 4, for 700.1600	10
700.1609	Spindle, for 700.1600	130
700.1610	Traverse, for 700.1600	345
700.1611	Nut set for tie rod, 2 pcs	10

BEARING AND BUSH DRIVER

Brass and aluminium punch

- For extracting bearing, bolts and bushes etc.
- Rimed handle for better control
- Brass / Aluminium



	Material	Ø mm	Length mm		€
156.0415	brass	20,0	300,0	1,13	46,50
156.0416	aluminium	30,0	300,0	1,89	27,90





Bearing punch set Ø 10.0 - 14.0 mm

- In durable plastic storage case



		kg	€
156.0440	10 pcs Bearing punch set Ø 10.0 - 14.0 mm	240	72,90

consists of:

		kg	€
156.0436	Punch holder without impact, with hand protection	100	
156.0441	Polyamide punch adaptor set, 2 pcs, Ø10mm	10	
156.0442	Polyamide punch adaptor set, 2 pcs, Ø12mm	10	
156.0443	Polyamide punch adaptor set, 2 pcs, Ø14mm	10	
156.0449	Aluminium punch adaptor set, 2 pcs, Ø10mm	10	
156.0450	Aluminium punch adaptor set, 2 pcs, Ø12mm	10	
156.0451	Aluminium punch adaptor set, 2 pcs, Ø14mm	20	
156.0457	Brass punch adaptor set, 2 pcs, Ø 10mm	20	
156.0458	Punch attachable head 2 pcs, brass, Ø 12 mm	20	
156.0459	Punch attachable head 2 pcs, brass, Ø 14 mm	50	

Bearing punch set Ø 25.0 mm

- In durable plastic storage case



		kg	€
156.0425	7 pcs Bearing punch set Ø 25.0 mm	640	68,50

consists of:

		kg	€
156.0426	Punch holder without impact	360	
156.0447	Polyamide punch adaptor set, 2 pcs, Ø25mm	20	
156.0455	Aluminium punch adaptor set, 2 pcs, Ø25mm	50	
156.0463	Punch attachable head 2 pcs, brass, Ø 25 mm	150	

Universal bearing and bush driver set

- Universal applicable range
- Can be used manually with a hammer or workshop press
- Applications from 18.0 - 65.0 mm
- Pressure plates are for the two driving spindles
- Special tool steel
- In durable plastic storage case



		kg	€
700.1350	51 pcs Universal bearing and bush driver set	8,00	394,90

consists of:

		kg	€
700.1348	Reception adaptor, 45mm	500	
700.1349	Impact drive knurled grip, 220mm	42	
700.1351	Pressure plate, 18mm	12	
700.1352	Pressure plate, 19mm	14	
700.1353	Pressure plate, 20mm	16	
700.1354	Pressure plate, 21mm	20	
700.1355	Pressure plate, 22mm	22	
700.1356	Pressure plate, 23mm	27	
700.1357	Pressure plate, 24mm	30	
700.1358	Pressure plate, 25mm	34	
700.1359	Pressure plate, 26mm	38	
700.1360	Pressure plate, 27mm	43	
700.1361	Pressure plate, 28mm	47	
700.1362	Pressure plate, 29mm	50	
700.1363	Pressure plate, 30mm	53	
700.1364	Pressure plate, 31mm	59	
700.1365	Pressure plate, 32mm	65	
700.1366	Pressure plate, 33mm	68	
700.1367	Pressure plate, 34mm	72	
700.1368	Pressure plate, 35mm	77	
700.1369	Pressure plate, 36mm	82	
700.1370	Pressure plate, 37mm	89	
700.1371	Pressure plate, 38mm	94	
700.1372	Pressure plate, 39mm	97	
700.1373	Pressure plate, 40mm	105	
700.1374	Pressure plate, 41mm	111	
700.1375	Pressure plate, 42mm	119	
700.1376	Pressure plate, 43mm	125	
700.1377	Pressure plate, 44mm	132	
700.1378	Pressure plate, 45mm	138	
700.1379	Pressure plate, 46mm	144	
700.1380	Pressure plate, 47mm	153	
700.1381	Pressure plate, 48mm	159	
700.1382	Pressure plate, 49mm	165	
700.1383	Pressure plate, 50mm	172	
700.1384	Pressure plate, 51mm	181	
700.1385	Pressure plate, 52mm	188	
700.1386	Pressure plate, 53mm	196	
700.1387	Pressure plate, 54mm	205	
700.1388	Pressure plate, 55mm	213	
700.1389	Pressure plate, 56mm	221	
700.1390	Pressure plate, 57mm	231	
700.1391	Pressure plate, 58mm	238	
700.1392	Pressure plate, 59mm	247	
700.1393	Pressure plate, 60mm	258	
700.1394	Pressure plate, 61mm	266	
700.1395	Pressure plate, 62mm	276	
700.1396	Pressure plate, 63mm	284	
700.1397	Pressure plate, 64mm	294	
700.1398	Pressure plate, 65mm	305	
700.1399	Support plate, 75mm	500	

Universal bearing and bush driver set

- for gentle driving of bearing and radial sealing rings
- Universal applicable range
- Can be used manually with a hammer or workshop press
- Applications from 70.0 - 150.0 mm
- Pressure plates are for the two driving spindles
- Special tool steel
- In durable plastic storage case



		kg	€
150.9710	21 pcs Universal bearing and bush driver set	19,13	787,50

consists of:

		kg	€
150.9712	Adaptor for Hydraulic thrust bolt, 45,5 mm	44	
150.9713	Retaining adapter, 55 mm	217	
150.9714	Repellent spike with knurling, 273,0 mm	1077	
150.9715	Pressure plate, 70 mm	353	
150.9716	Pressure plate, 75 mm	406	
150.9717	Pressure plate, 80 mm	465	
150.9718	Pressure plate, 85 mm	524	
150.9719	Pressure plate, 90 mm	593	
150.9720	Pressure plate, 95 mm	659	
150.9721	Pressure plate, 100 mm	733	
150.9722	Pressure plate, 105 mm	812	
150.9723	Pressure plate, 110 mm	893	
150.9724	Pressure plate, 115 mm	977	
150.9725	Pressure plate, 120 mm	1065	
150.9726	Pressure plate, 125 mm	1157	
150.9727	Pressure plate, 130 mm	1255	
150.9728	Pressure plate, 135 mm	1349	
150.9729	Pressure plate, 140 mm	1457	
150.9730	Pressure plate, 145 mm	1563	
150.9731	Pressure plate, 150 mm	1676	
151.2603	Hexagon key wrench phosphate finish, short, 3mm	10	

POLE TERMINAL EXTRACTOR

Universal pole terminal and wiper arm puller 2-arm pattern

- 2-jaw
- ideally suited for removing the battery terminal and wiper arms
- Locking handle
- With conical tension screw for proportional tension force distribution
- Self-centring jaw puller
- Extremely robust spindle with inductively hardened thread
- Special tool steel

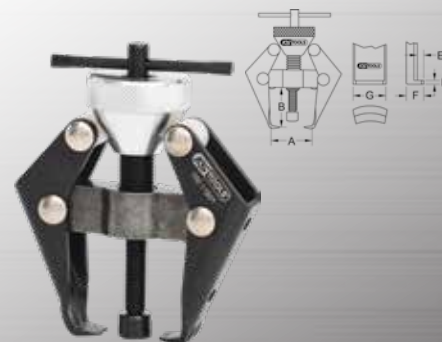

		A	B	max t	D	E	F	G	kg	€	
700.1190		15	32	1,2	M8 x 50	2,5	9	10,5	11	0,30	34,50

Pole clamp 2-jaw puller

- 2-jaw
- Ideally suited for removing the battery pole terminal
- Automatic pressure on the legs
- Extremely robust spindle with inductively hardened thread
- Screwed
- Sturdy hook
- Special tool steel

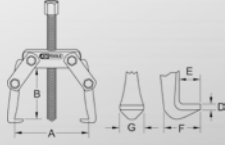

	A mm	B mm	max. t	mm	D mm	E mm	F mm	G mm	g	€	
620.3101	10-60	40	1	M8x85	10	1	5	12	8	160	29,90
620.3102	10-70	44/74	1,2	M8x85	10	1	5	12	8	200	34,50
620.3103	10-90	84	2	M10x105	12	1,8	10	20	12	340	39,50

3-jaw pole terminal extractor with t-bar

- 3-jaw
- Ideally suited for removing the battery pole terminal
- Locking handle
- Automatic pressure on the legs
- Extremely robust spindle with inductively hardened thread
- Screwed
- Sturdy hook
- Special tool steel

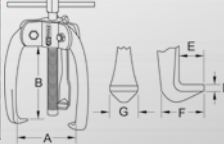

	A mm	B mm	max. t	mm	D mm	E mm	F mm	G mm	g	€
700.1167	10-60	40	0,75	M10 x 60	2,3	5,5	12,3	10,0	181	46,50
700.1168	10-60	60	1,0	M10 x 80	3,0	5,5	12,5	10,0	215	52,50
700.1169	10-70	80	1,0	M10 x 100	3,0	8,0	15,2	14,1	323	54,50

Pole clamp 3 arm puller

- Uniform load distribution and centered tightening
- Ideally suited for extracting small parts
- Automatic pressure on the legs
- Extremely robust spindle with inductively hardened thread
- Special tool steel

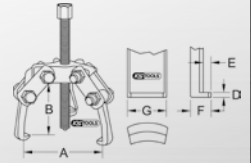

	A mm	B mm	max. t	mm	D mm	E mm	F mm	G mm	g	€	
630.3101	10-60	40	1,2	M8 x 85	10	1	5	12	8	0,20	33,50
630.3102	10-70	44/74	1,3	M8 x 85	10	1	5	12	8	0,30	36,50
630.3103	10-90	84	2,5	M10 x 105	12	1,8	10	20	12	0,50	44,90

Universal pole terminal and wiper arm puller 2-arm pattern

- 2-jaw
- ideally suited for removing the battery terminal and wiper arms
- Locking handle
- Automatic pressure on the legs
- Extremely robust spindle with inductively hardened thread
- Screwed
- Sturdy hook
- Special tool steel

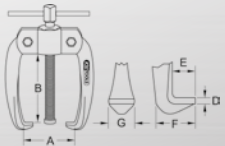

	A mm	B mm	max. t	mm	D mm	E mm	F mm	G mm	g	€
700.1164	10-60	40	0,5	M10 x 60	2,6	5,5	12,8	10,0	145	39,50
700.1165	10-60	60	0,5	M10 x 80	3,7	5,8	12,4	10,1	173	39,50
700.1166	10-70	80	0,5	M10 x 100	4,0	9,2	16,8	14,0	245	42,90

Universal windscreen wiper arm puller 2-jaw with t-bar

- Heavy execution
- 2-jaw
- Ideally suited to the protective removal of windscreen wiper arms
- Locking handle
- With narrow socket for tight spaces
- With conical self-tensioning clamping screws for proportional tension force distribution
- Self-centring jaw puller
- Extremely robust spindle with inductively hardened thread
- Special tool steel

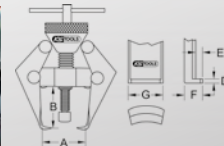

	A mm	B mm	max. t	mm	D mm	E mm	F mm	G mm	g	€
700.1179	45	37	1,2	M10 x 105	5	8	16	8	284	40,90

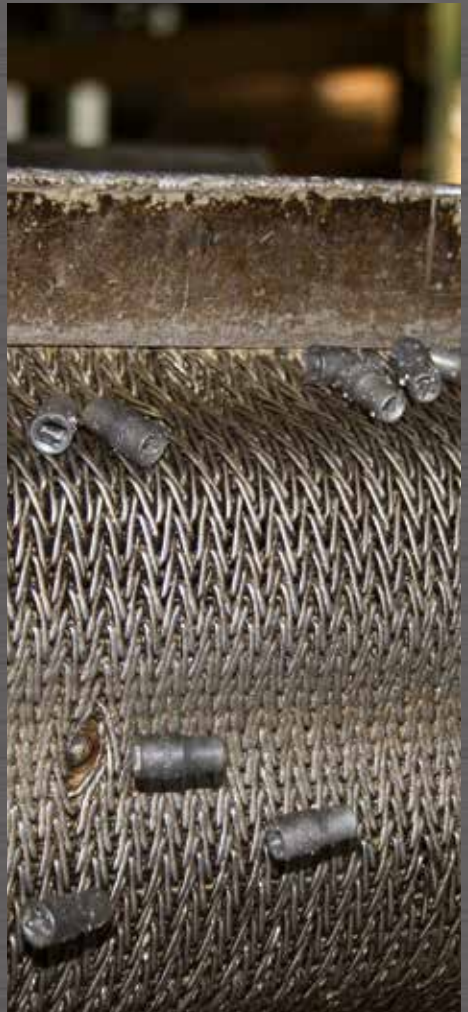

UNIVERSAL 2 ARM PULLER

Universal 2 arm puller

- Robust spindle with hexagon drive
- 640.4103 with locking handle
- Special tool steel



	A mm	B mm	max t mm	mm	D mm	E mm	F mm	G mm	kg	€	
620.4101	10-60	45	2,5	M10x1 x 90	12	2	9	18	10	270	38,50
620.4102	10-70	65	3	M10x1 x 110	12	2	9	18	10	300	39,50
620.4103	10-100	80	3,5	M12x1,25 x 140	14	2,3	12	25	13	610	40,90

Universal 2 arm puller

- for the removal of small parts
- Ideal for confined spaces
- Uniform load distribution and centered tightening
- Pulling hooks are automatically pressed against the part to be pulled off
- Extremely robust spindle with inductively hardened thread
- Special tool steel



	A mm	B mm	max t mm	mm	D mm	E mm	F mm	G mm	kg	€	
620.0073	10-50	40	1	M8x85	10	1,5	6,5	15	8,5	200	41,90
620.0074	10-50	40	1	M8x85	10	2,2	7	12	12	200	57,90



Universal windscreen wiper arm puller set 2/4-jaws

- 2/4-jaws
- each with 2 extra-slim size and pairs of arms with varying width
- Ideally suited to removal of windscreen wiper arms
- Pulling spindle for damage-free support to the rear wiper blades
- Option of working with wide or narrow arms
- Ball bearing mounted centring point
- With narrow socket for tight spaces
- Prevents damage to the bodywork and the windscreen wiper arm
- External drive hexagonal socket 13.0 mm
- Special tool steel



			kg	€
700.1242	6 pcs	Universal windscreen wiper arm puller set 2/4-jaws	690	75,90

consists of:

	X	kg
700.1245	1 Spindle M12 x 90 mm for 700.1242	150
700.1246	1 Traverse arm, 6 point	100
700.1247	2 Puller arm – slim type	100
700.1248	2 Puller arm – wide type	100

Universal 2 arm puller

- Legs are adjustable in the working depth
- Automatic pressure on the legs
- Extremely robust spindle with inductively hardened thread
- Special tool steel

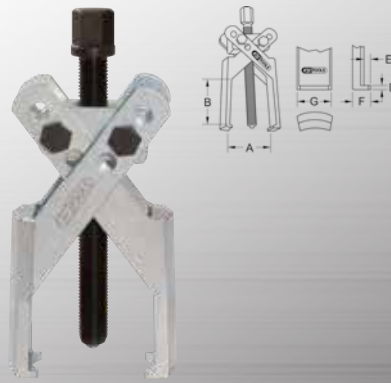

	A mm	B mm	max t mm	mm	D mm	E mm	F mm	G mm	kg	€	
620.5201	6-100	70/85	1,5	M10 x 105	12	2,5	4,5	8,5	23	0,40	101,90
620.5202	10- 140	85/120	3,5	M14x1,5 x 130	17	3,5	5	10	31	0,90	123,50
620.5203	15- 140	125/155	4,5	M14x1,5 x 200	17	3,5	5	10	31	1,10	141,50

Universal 2 arm puller set with narrow legs

- Legs are adjustable in the working depth
- Ideal for confined spaces
- Automatic pressure on the legs
- Extremely robust spindle with inductively hardened thread
- Special tool steel

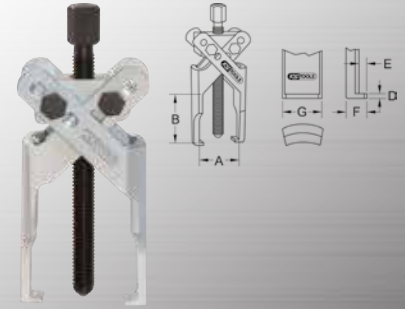

	A mm	B mm	max t mm	mm	D mm	E mm	F mm	G mm	kg	€	
620.5301	6-100	70/85	1	M10 x 105	12	2,5	4,5	8,5	11	0,40	119,90
620.5302	15- 140	125/155	2	M14x1,5 x 200	17	3,5	5	11	12	1,00	186,50

Basic universal 2 arm puller

- Extremely robust spindle with inductively hardened thread
- Special tool steel



	A mm	B mm	max t mm	mm	D mm	E mm	F mm	G mm	kg	€	
620.4301	10-100	80	2,5	M12x1,25 x 162	14	4	12	26	13	0,68	46,50
620.4302	10-120	120	3	M14x1,5 x 193	17	5	14	30	16	1,14	70,90
620.4303	20-160	160	3,5	M18x1,5 x 243	19	6	18	36	20	2,00	109,50
620.4304	20-200	200	4	M22x2 x 293	24	7	22	40	24	3,50	142,50

Universal 2 arm puller

- Legs double ended usable
- Extremely robust spindle with inductively hardened thread
- Special tool steel

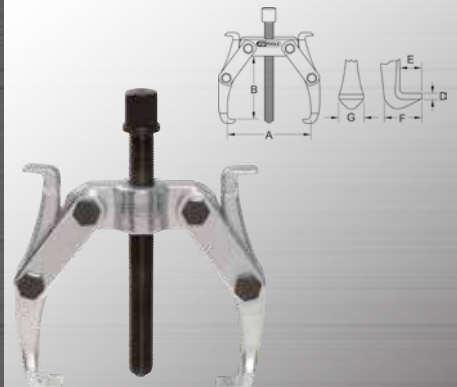

	A mm	B mm	max t mm	mm	D mm	E mm	F mm	G mm	kg	€	
620.3001	20-150	85	3,5	M14x1,5 x 130	17	2	9	21	12	0,90	57,90
620.3002	40-220	130	4	M18x1,5 x 240	19	4	11	25	21	2,20	98,50

Universal 2 arm puller

- Legs are adjustable in the working depth
- Extremely robust spindle with inductively hardened thread
- Special tool steel

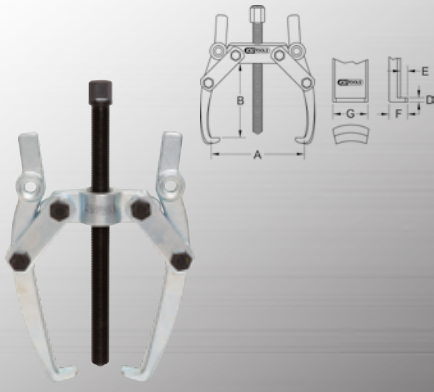

	A mm	B mm	max t	mm	D mm	E mm	F mm	G mm	kg	€
620.3401	20-170	130	3,5	M14x1,5 x 130	17	2	11	23	1,00	54,50
620.3402	20-230	200	4	M18x1,5 x 240	19	4,5	16	33	2,30	88,90

Universal bearing ring puller 2 arm with clamping yoke

- Clamping yoke compresses the legs firmly
- Prevents slipping
- Pressure peak centers itself optimally in the cone of the hub boring
- Extremely robust spindle with inductively hardened thread
- Special tool steel

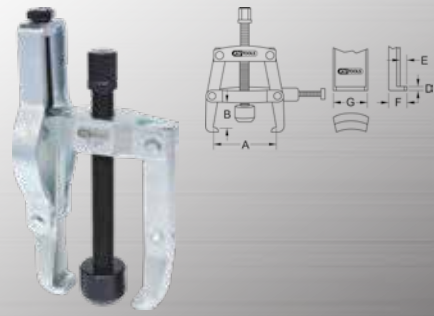

	A mm	B mm	max t	mm	D mm	E mm	F mm	G mm	kg	€	
700.1260	90	100	1,2	M16 x 150	17	6,5	8,5	22,5	27,1	1,76	97,50

Universal 2 arm puller set with clamping yoke

- Shearing action increases the pressing power when removing
- Clamping yoke compresses the legs firmly
- Prevents slipping
- Extremely robust spindle with inductively hardened thread
- Special tool steel

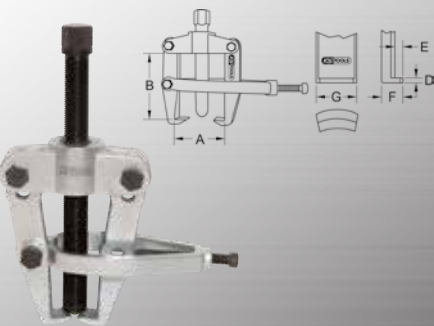

	A mm	B mm	max t	mm	D mm	E mm	F mm	G mm	kg	€	
620.5401	80	90	5	M18 x 1,5 x 130	19	3	12	26	24	1,70	104,90
620.5402	100	110	6	G1/2"x14g x 210	22	3	14	25	24	2,60	120,90
620.5403	150	150	8	G1/2"x14g x 210	22	3	14	25	24	3,40	178,90

Universal 2 arm puller set with clamping yoke

- Legs are adjustable in the working depth
- Legs double ended usable
- Clamping yoke compresses the legs firmly
- Prevents slipping
- Ideally suited for flush sitting bearings and bushes
- Extremely robust spindle with inductively hardened thread
- Special tool steel

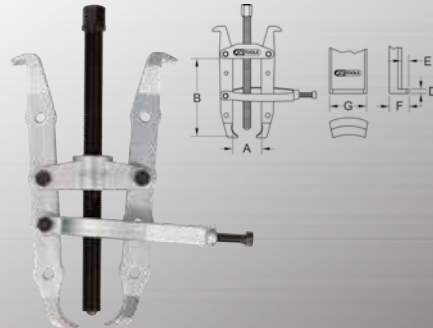

	A mm	B mm	max t	mm	D mm	E mm	F mm	G mm	kg	€	
620.5501	110	170	5	M18x1,5 x 240	19	3	12	25	24	2,30	180,90
620.5502	150	270	6	G1/2"x14g x 270	22	3	14	25	24	4,10	224,90
620.5503	150	330	8	G1/2"x14g x 270	22	3	14	25	24	4,50	257,90

Universal 2 arm puller set with hardened steel legs

- Through reversing the arms internal and external applications are possible
- Hydraulic spindles available for thread G1/2" / G3/4"
- Extremely robust spindle with inductively hardened thread
- Special tool steel

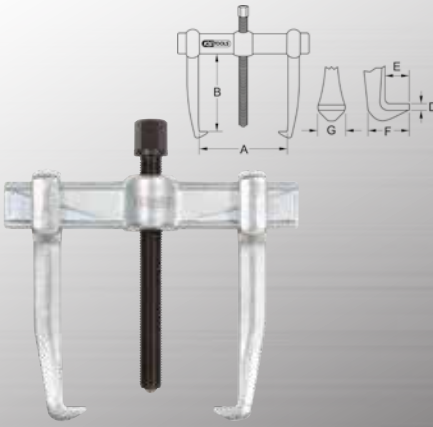

	A mm	B mm	C mm	max t	mm	D mm	E mm	F mm	G mm	kg	€
620.1301	15-80	100	70-130	3,5	M14x1,5 x 130	17	3	12	22	0,90	68,50
620.1302	15-120	100	80-170	3,5	M14x1,5 x 130	17	3	12	22	1,00	72,90
620.1303	20-160	150	110-210	6	G1/2"x14g x 210	22	4	16	30	2,70	103,90
620.1304	20-200	150	120-250	6	G1/2"x14g x 210	27	4	16	30	3,00	127,50
620.1305	40-250	200	170-300	8	G3/4"x14g x 280	27	6,5	23	43	6,50	238,90
620.1306	40-350	200	190-400	8	G3/4"x14g x 280	27	6,5	23	43	7,60	261,50



Universal 2 arm puller

- Through reversing the arms internal and external applications are possible
- Hydraulic spindles available for thread G1/2" / G3/4" / G1"
- Extremely robust spindle with inductively hardened thread
- Special tool steel

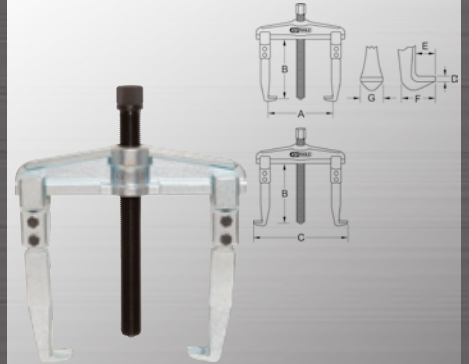

	A mm	B mm	C mm	max t	mm	D mm	E mm	F mm	G mm	kg	€	
620.0101	20-90	100	70-130	4,5	M14x1,5 x 140	17	3	13	25	20	1,00	72,90
620.0102	25-130	100	80-180	4,5	M14x1,5 x 140	17	3	13	25	20	1,20	78,50
620.0103	50-160	150	105-220	6,5	G1/2"x14g x 210	22	4	16	35	25	3,00	131,90
620.0104	60-200	150	120-270	6,5	G1/2"x14g x 210	22	4	16	35	25	3,30	144,50
620.0105	80-250	200	160-330	11	G3/4"x14g x 280	27	5	25	54	35	7,40	239,90
620.0106	80-350	200	160-420	11	G3/4"x14g x 280	27	5	25	54	35	8,50	261,50
620.0107	110-520	200	195-600	13	G3/4"x14g x 280	27	5	25	54	35	13,00	402,50
620.0108	170-640	225	250-720	18	G1"x11g x 310	36	10	33	55	50	23,70	943,90

Universal 2 arm puller

- Legs are adjustable in the working depth
- Hydraulic spindles available for thread G1/2"
- Extremely robust spindle with inductively hardened thread
- Special tool steel

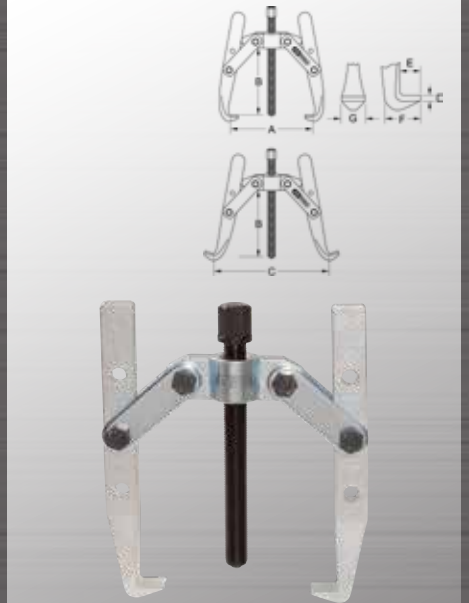

	A mm	B mm	max t	mm	D mm	E mm	F mm	G mm	kg	€	
620.3601	18-100	85	2,5	M10 x 105	12	2	10	20	14	0,40	40,90
620.3602	20-200	150	3,5	M14x1,5 x 130	17	3	14	25	18	1,20	55,90
620.3603	35-250	220	4	M18x1,5 x 240	19	4	20	35	25	2,80	92,50
620.3604	50-300	250	6	G1/2"x14g x 270	22	5	25	48	30	5,40	148,90
620.3605	50-350	350	6	G1/2"x14g x 270	22	5	25	48	30	6,10	176,50
620.3606	50-400	400	6	G1/2"x14g x 270	22	5	25	48	30	6,40	227,90
620.3607	50-450	450	6	G1/2"x14g x 270	22	5	25	48	30	6,90	251,50
620.3608	50-500	500	6	G1/2"x14g x 270	22	5	25	48	30	7,00	209,90
620.3609	50-500	650	6	G1/2"x14g x 270	22	5	25	48	30	8,40	239,90
620.3610	50-500	1000	6	G1/2"x14g x 270	22	5	25	48	30	11,00	302,90

Hydraulic universal 2 arm puller

- Legs are adjustable in the working depth
- Different leg variants available
- Includes hydraulic thrust spindle
- Excellent power transfer
- Special tool steel

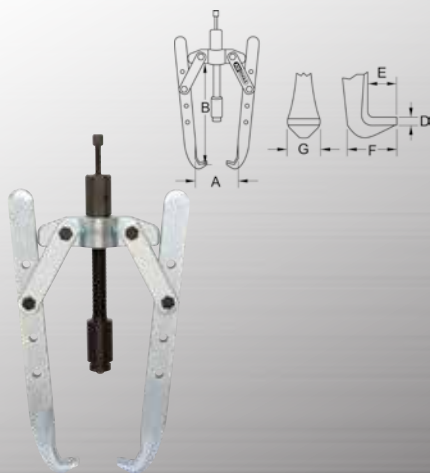

	A mm	B mm	max t	Hydraulic spindle mm	D mm	E mm	F mm	G mm	kg	€	
620.3801	50-300	175	12	615.0002	32	5	25	48	30	5,70	331,90
620.3802	50-350	275	12	615.0002	32	5	25	48	30	6,40	360,50
620.3803	50-400	325	12	615.0002	32	5	25	48	30	6,70	367,50
620.3804	50-450	375	12	615.0002	32	5	25	48	30	7,20	380,90
620.3805	50-500	425	12	615.0002	32	5	25	48	30	7,30	393,90
620.3806	50-500	575	12	615.0002	32	5	25	48	30	8,70	423,90

Universal 2 + 3 arm puller

- Legs double ended usable
- Through reversing the arms internal and external applications are possible
- Reception star for 2 or 3 hooks
- Extremely robust spindle with inductively hardened thread
- Special tool steel



	A mm	B mm	C mm	max t	Hydraulic spindle mm	D mm	E mm	F mm	G mm	kg	€	
640.4203	60	65	90	2,0	G3/8" x 1,06x110	13	3	10	18	11	0,47	58,90
640.4204	90	100	130	5,0	G3/16" x 2,0px190	17	4	15,5	29	17	1,60	102,90
640.4205	165	170	170	7,0	G3/4" x 2,0px285	22	4	15,5	29	17	3,20	133,90

Universal puller 2 and 3 arm

- Legs double ended usable
- Reception star for 2 or 3 hooks
- Extremely robust spindle with inductively hardened thread
- Special tool steel



	A mm	B mm	max t	Hydraulic spindle mm	D mm	E mm	F mm	G mm	kg	€	
700.1120	70	75	1,2	3/8"x24g x 120	13	3,2	8,4	20	8,4	0,96	28,90
700.1130	120	150	1,2	M14x1,25 x 175	16	7,2	7	17,8	7,0	1,83	46,50

Hydraulic universal 2 arm puller

- Through reversing the arms internal and external applications are possible
- Different leg variants available
- Includes hydraulic thrust spindle
- Lower power usage
- Special tool steel

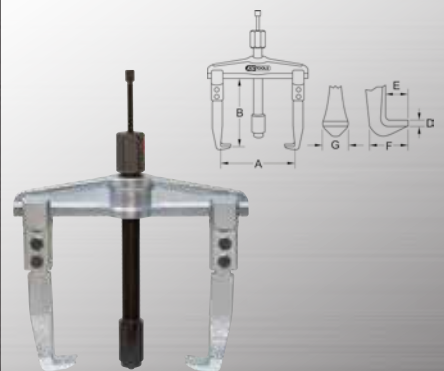

	A mm	B mm	C mm	max t	Hydraulic spindle mm	D mm	E mm	F mm	G mm	kg	€	
620.0301	50-160	145	105-220	12	615.0002	32	4	16	35	25	3,40	297,50
620.0302	50-200	145	120-270	12	615.0002	32	4	16	35	25	3,80	311,50
620.0303	80-250	125	160-330	12	615.0003	36	5	25	54	35	8,00	448,50
620.0304	80-350	125	160-420	12	615.0003	36	5	25	54	35	9,00	474,50
620.0305	110-520	125	195-600	12	615.0003	36	5	25	54	35	13,50	604,50
620.0306	170-640	125	250-720	12	615.0003	36	5	25	54	35	21,00	929,90
620.0307	170-640	210	250-720	15	615.0004	41	10	33	55	50	27,00	1151,50



Universal 2 arm puller set with extended legs

- Through reversing the arms internal and external applications are possible
- Hydraulic spindles available for thread G1/2" / G3/4"
- Extremely robust spindle with inductively hardened thread
- Special tool steel

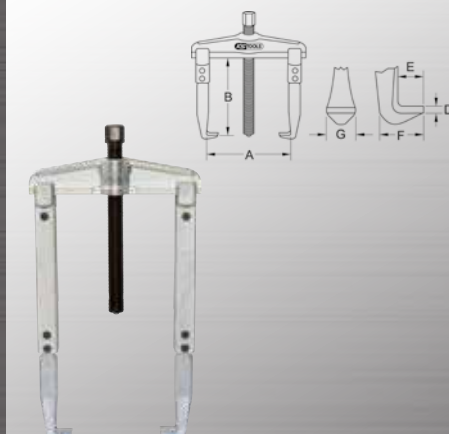

	A mm	B mm	C mm	max t	Hydraulic spindle mm	D mm	E mm	F mm	G mm	kg	€	
620.0501	20-90	200	70-130	4,5	M14x1,5 x 140	17	3	13	25	20	1,50	87,90
620.0502	25-130	200	80-180	4,5	M14x1,5 x 140	17	3	13	25	20	1,70	93,50
620.0503	50-160	300	105-220	6,5	G1/2"x14g x 210	22	4	16	35	25	4,00	159,50
620.0504	60-200	300	120-270	6,5	G1/2"x14g x 210	22	4	16	35	25	4,30	173,50
620.0505	80-250	300	160-330	11	G3/4"x14g x 280	27	5	25	54	35	9,20	293,50
620.0506	100-350	300	160-420	11	G3/4"x14g x 280	27	5	25	54	35	10,30	318,90
620.0507	110-520	300	195-600	13	G3/4"x14g x 280	27	5	25	54	35	14,80	448,50
620.0508	80-250	400	160-330	11	G3/4"x14g x 280	27	5	25	54	35	10,50	327,50
620.0509	80-350	400	160-420	11	G3/4"x14g x 280	27	5	25	54	35	11,60	353,50
620.0510	110-520	400	195-600	13	G3/4"x14g x 280	27	5	25	54	35	16,10	482,50
620.0511	80-250	500	160-330	11	G3/4"x14g x 280	27	5	25	54	35	11,90	337,50
620.0512	80-350	500	160-420	11	G3/4"x14g x 280	27	5	25	54	35	13,00	361,90
620.0513	110-520	500	195-600	13	G3/4"x14g x 280	27	5	25	54	35	17,50	492,50

Hydraulic universal 2 arm puller

- Through reversing the arms internal and external applications are possible
- Hydraulic spindles available for thread G1/2"
- Includes hydraulic thrust spindle
- Lower power usage
- Special tool steel

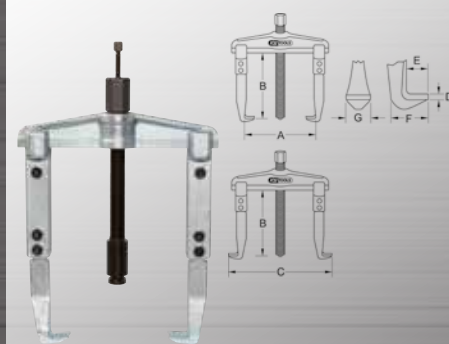

	A mm	B mm	C mm	max t	Hydraulic spindle mm	D mm	E mm	F mm	G mm	kg	€	
620.0701	50-160	225	105-220	12	615.0002	13	4	16	35	25	3,90	323,50
620.0702	50-200	225	120-270	12	615.0002	13	4	16	35	25	4,80	337,50
620.0703	80-250	225	160-330	12	615.0002	13	5	25	54	35	9,80	466,50
620.0704	80-350	225	160-420	12	615.0002	13	5	25	54	35	10,80	499,90
620.0705	110-520	225	195-600	12	615.0002	13	5	25	54	35	15,30	574,50
620.0706	80-250	325	160-330	12	615.0002	13	5	25	54	35	11,10	476,50
620.0707	80-350	325	160-420	12	615.0002	13	5	25	54	35	12,10	510,50
620.0708	110-520	325	195-600	12	615.0002	13	5	25	54	35	16,60	597,50
620.0709	80-250	425	160-330	12	615.0002	13	5	25	54	35	12,50	502,90
620.0710	80-350	425	160-420	12	615.0002	13	5	25	54	35	13,50	528,50
620.0711	110-520	425	195-600	12	615.0002	13	5	25	54	35	18,00	604,50

Quick release universal 2 arm puller

- Quick release function
- Through reversing the arms internal and external applications are possible
- Hydraulic spindles available for thread G1/2" / G3/4"
- Extremely robust spindle with inductively hardened thread
- Special tool steel

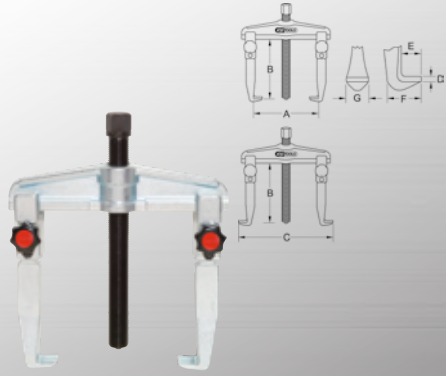

	A mm	B mm	C mm	max t	Hydraulic spindle	D mm	E mm	F mm	G mm	kg	€	
620.1701	20-90	100	70-130	4,5	M14x1,5 x 130	17	3	13	25	20	1,00	72,90
620.1702	25-130	100	80-180	4,5	M14x1,5 x 130	17	3	13	25	20	1,20	78,50
620.1703	50-160	150	108-220	6,5	G1/2"x14g x 210	22	4	16	35	25	3,00	131,90
620.1704	60-200	150	120-270	6,5	G1/2"x14g x 210	22	4	16	35	25	3,30	144,50
620.1705	80-250	200	160-330	11	G3/4"x14g x 280	27	5	25	54	35	7,40	239,90
620.1706	80-350	200	160-420	11	G3/4"x14g x 280	27	5	25	54	35	8,50	261,50

Hydraulic quick release universal 2 arm puller

- Quick release function
- Through reversing the arms internal and external applications are possible
- Different leg variants available
- Includes hydraulic thrust spindle
- Excellent power transfer
- Special tool steel

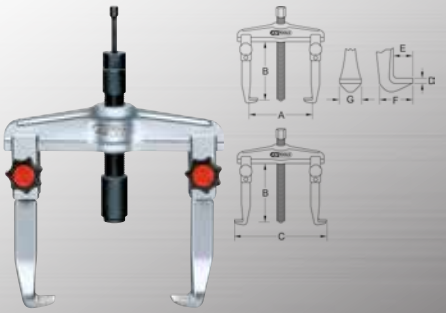

	A mm	B mm	C mm	max t	Hydraulic spindle	D mm	E mm	F mm	G mm	kg	€	
620.1901	50-160	145	105-220	12	615.0003	32	4	16	35	25	3,40	297,50
620.1902	50-200	145	120-270	12	615.0003	32	4	16	35	25	3,80	311,50
620.1903	80-250	125	160-330	12	615.0004	32	5	25	54	35	8,00	448,50
620.1904	80-350	125	160-420	12	615.0004	32	5	25	54	35	9,00	474,50



Hydraulic quick release universal 2 arm puller with extended legs

- Quick release function
- Long execution
- even load distribution and centered pull-off
- Through reversing the arms internal and external applications are possible
- Different leg variants available
- Includes hydraulic thrust spindle
- Lower power usage
- Special tool steel

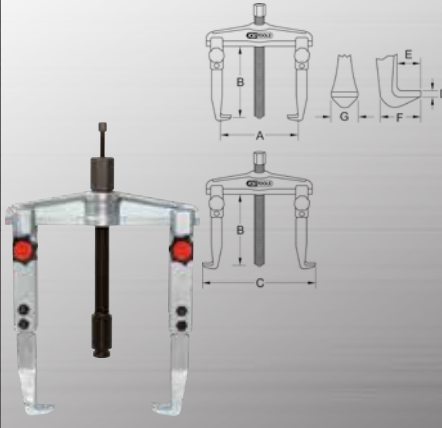

	A mm	B mm	C mm	max t	Hydraulic spindle	D mm	E mm	F mm	G mm	kg	€	
620.0075	80-250	225	160-330	12	615.0003	13	5	25	54	35	9,80	636,90
620.0076	80-250	325	160-330	12	615.0003	13	5	25	54	35	11,10	691,50
620.0077	80-250	425	160-330	12	615.0003	13	5	25	54	35	12,50	731,90
620.0078	80-350	225	160-420	12	615.0003	13	5	25	54	35	10,80	688,50
620.0079	80-350	325	160-420	12	615.0003	13	5	25	54	35	12,10	724,50
620.0081	80-350	425	160-420	12	615.0003	13	5	25	54	35	13,80	777,90
620.0082	110-520	225	195-600	12	615.0003	13	5	25	54	35	15,30	870,90
620.0083	110-520	325	195-600	12	615.0003	13	5	25	54	35	16,60	907,50
620.0084	110-520	425	195-600	12	615.0003	13	5	25	54	35	18,30	959,90
620.0085	140-640	225	225-715	12	615.0003	13	5	25	54	35	19,80	1185,50
620.0086	140-640	325	225-715	12	615.0003	13	5	25	54	35	21,10	1226,50
620.0087	140-640	425	225-715	12	615.0003	13	5	25	54	35	22,50	1273,50

Universal 2 arm puller set with extremely narrow legs

- Narrow execution
- extremely pointed hook foot
- Ideal for confined spaces
- Uniform load distribution and centered tightening
- Through reversing the arms internal and external applications are possible
- Wide range of arms and hydraulic spindles available
- Extremely robust spindle with inductively hardened thread
- Special tool steel

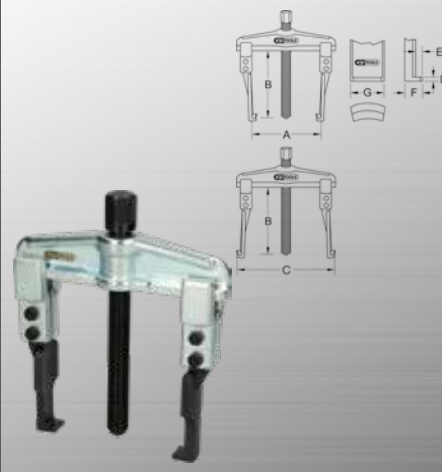

	A mm	B mm	C mm	max t	Hydraulic spindle	D mm	E mm	F mm	G mm	kg	€	
620.0041	20-90	100	70-130	2,5	M14x1,5 x 130	17	3,6	8	14	14	1,00	85,50
620.0042	25-130	100	80-180	2,5	M14x1,5 x 130	17	3,6	8	14	14	1,20	85,50
620.0043	50-160	150	105-220	5	G1/2"x14 x 210	22	5	7,5	15	27	2,90	144,50
620.0044	60-200	150	120-270	5	G1/2"x14 x 210	22	5	7,5	15	27	3,20	156,50

Universal 2 arm puller set with narrow legs

- Ideal for confined spaces
- Uniform load distribution and centered tightening
- Through reversing the arms internal and external applications are possible
- Wide range of arms and hydraulic spindles available
- Extremely robust spindle with inductively hardened thread
- Special tool steel



	A mm	B mm	C mm	max t	Hydraulic spindle	D mm	E mm	F mm	G mm	kg	€	
620.0023	20-90	100	90-170	3,5	M14x1,5 x 130	17	2	8	14	28	1,00	80,50
620.0024	25-130	100	95-175	3,5	M14x1,5 x 130	17	2	8	14	28	1,20	85,50
620.0901	20-90	100	70-130	4,5	M14x1,5 x 140	17	3,6	6	13	27	1,00	93,50
620.0902	25-130	100	80-180	4,5	M14x1,5 x 140	17	3,6	6	13	27	1,20	97,50
620.0903	50-160	150	105-220	6,5	G1/2"x14g x 210	22	5	8	17	40	3,00	162,90
620.0904	60-200	150	120-270	6,5	G1/2"x14g x 210	22	5	8	17	40	3,30	178,90

Universal 2 arm puller set with extremely narrow and extended legs

- extremely pointed hook foot
- Ideal for confined spaces
- Long execution
- Uniform load distribution and centered tightening
- Through reversing the arms internal and external applications are possible
- Wide range of arms and hydraulic spindles available
- Extremely robust spindle with inductively hardened thread
- Special tool steel

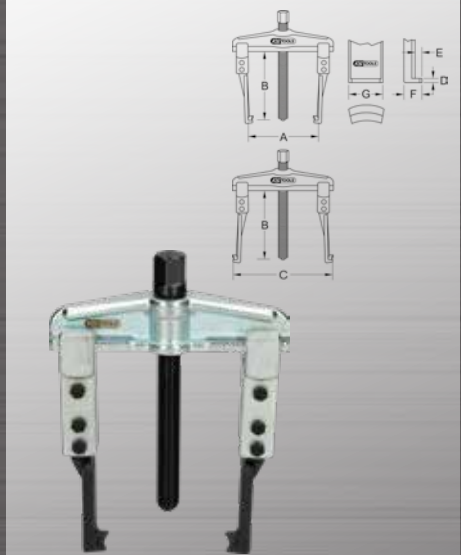

	A mm	B mm	C mm	max t	Hydraulic spindle	D mm	E mm	F mm	G mm	kg	€	
620.0027	20-90	120	70-130	3,5	M14x1,5 x 130	17	2	8	14	28	1,10	93,50
620.0028	20-90	200	70-130	3,5	M14x1,5 x 130	17	2	8	14	28	1,50	93,50
620.0029	20-90	250	70-130	3,5	M14x1,5 x 130	17	2	8	14	28	1,70	99,50
620.0031	25-130	120	80-180	3,5	M14x1,5 x 130	17	2	8	14	28	1,30	97,50
620.0032	25-130	200	80-180	3,5	M14x1,5 x 130	17	2	8	14	28	1,70	97,50
620.0033	25-130	250	80-180	3,5	M14x1,5 x 130	17	2	8	14	28	1,90	102,90

Universal 2 arm puller set with extremely narrow and extended legs

- Narrow execution
- Long execution
- extremely pointed hook foot
- Ideal for confined spaces
- Uniform load distribution and centered tightening
- Through reversing the arms internal and external applications are possible
- Wide range of arms and hydraulic spindles available
- Extremely robust spindle with inductively hardened thread
- Special tool steel

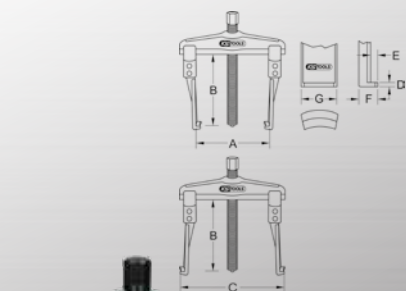

	A	B	C	max	mm	D	E	F	G	kg	€
	mm	mm	mm	t	mm	mm	mm	mm	mm		
620.0051	20-90	120	70-130	2.5	M14x1.5 x 130	17	3,6	8	14	1,10	97,50
620.0052	20-90	200	70-130	2.5	M14x1.5 x 130	17	3,6	8	14	1,50	98,50
620.0053	20-90	250	70-130	2.5	M14x1.5 x 130	17	3,6	8	14	1,70	103,90
620.0054	25-130	120	80-180	2.5	M14x1.5 x 130	17	3,6	8	14	1,30	102,90
620.0055	25-130	200	80-180	2.5	M14x1.5 x 130	17	3,6	8	14	1,70	102,90
620.0056	25-130	250	80-180	2.5	M14x1.5 x 130	17	3,6	8	14	1,90	109,50
620.0057	50-160	220	105-220	5	G1/2"x14 x 210	22	5	7,5	15	2,70	189,50
620.0058	50-160	300	105-220	5	G1/2"x14 x 210	22	5	7,5	15	2,70	189,50
620.0059	60-200	220	120-270	5	G1/2"x14 x 210	22	5	7,5	15	2,70	201,50
620.0061	60-200	300	120-270	5	G1/2"x14 x 210	22	5	7,5	15	2,70	202,50

Universal 2 arm puller set with narrow and extended legs

- Ideal for confined spaces
- Long execution
- Uniform load distribution and centered tightening
- Through reversing the arms internal and external applications are possible
- Wide range of arms and hydraulic spindles available
- Extremely robust spindle with inductively hardened thread
- Special tool steel

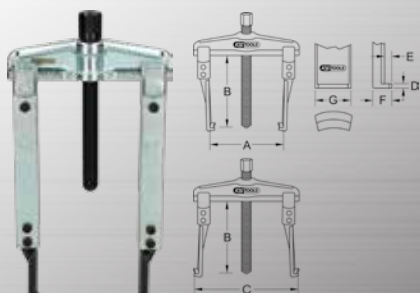

	A	B	C	max	mm	D	E	F	G	kg	€
	mm	mm	mm	t	mm	mm	mm	mm	mm		
620.0001	20-90	120	70-130	4.5	M14x1.5 x 130	17	3,6	8	14	1,10	93,50
620.0002	20-90	200	70-130	4.5	M14x1.5 x 130	17	3,6	8	14	1,50	93,50
620.0003	20-90	250	70-130	4.5	M14x1.5 x 130	17	3,6	8	14	1,70	99,50
620.0004	25-130	120	80-180	4.5	M14x1.5 x 130	17	3,6	8	14	1,30	97,50
620.0005	25-130	200	80-180	4.5	M14x1.5 x 130	17	3,6	8	14	1,70	97,50
620.0006	25-130	250	80-180	4.5	M14x1.5 x 130	17	3,6	8	14	1,90	103,90
620.0007	50-160	220	105-220	6.5	G1/2"x14 x 210	22	5	7,5	15	2,70	161,50
620.0008	50-160	300	105-220	6.5	G1/2"x14 x 210	22	5	7,5	15	2,70	161,50
620.0009	60-200	220	120-270	6.5	G1/2"x14 x 210	22	5	7,5	15	2,70	194,90
620.0011	60-200	300	120-270	6.5	G1/2"x14 x 210	22	5	7,5	15	2,70	195,90

Quick release universal 2 arm puller set with narrow legs

- Quick release function
- Ideal for confined spaces
- Through reversing the arms internal and external applications are possible
- Hydraulic spindles available for thread G1/2"
- Extremely robust spindle with inductively hardened thread
- Special tool steel

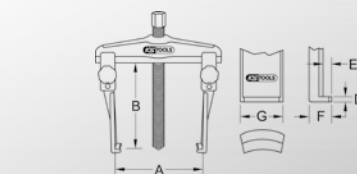

	A	B	C	max	mm	D	E	F	G	kg	€	
	mm	mm	mm	t	mm	mm	mm	mm	mm			
620.0025	20-90	100	70-130	3.5	M14x1.5 x 130	17	2	8	14	28	1,00	85,50
620.0026	25-130	100	80-180	3.5	M14x1.5 x 130	17	2	8	14	28	1,20	89,90
620.1101	20-90	100	70-130	4.5	M14x1.5 x 140	17	3,6	6	13	27	1,00	93,50
620.1102	25-130	100	80-180	4.5	M14x1.5 x 140	17	3,6	6	13	27	1,20	97,50
620.1103	50-160	150	105-220	6.5	G1/2"x14g x 210	22	5	8	17	40	3,00	162,90
620.1104	60-200	150	120-270	6.5	G1/2"x14g x 210	22	5	8	17	40	3,30	178,90

Quick adjustment universal 2 arm puller set with extremely narrow legs

- Quick release function
- Narrow execution
- extremely pointed hook foot
- Ideal for confined spaces
- Uniform load distribution and centered tightening
- Through reversing the arms internal and external applications are possible
- Wide range of arms and hydraulic spindles available
- Extremely robust spindle with inductively hardened thread
- Special tool steel

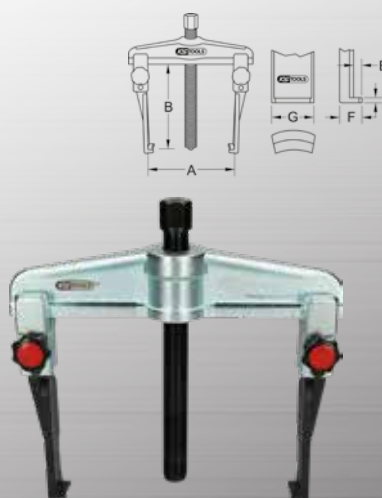

	A	B	C	max	mm	D	E	F	G	kg	€
	mm	mm	mm	t	mm	mm	mm	mm	mm		
620.0045	20-90	100	70-130	2.5	M14x1.5 x 130	17	3,6	8	14	1,00	89,90
620.0046	25-130	100	80-180	2.5	M14x1.5 x 130	17	3,6	8	14	1,20	95,50
620.0047	50-160	150	105-220	5	G1/2"x14 x 210	22	5	7,5	15	2,70	149,90
620.0048	60-200	150	120-270	5	G1/2"x14 x 210	22	5	7,5	15	2,70	162,90

Quick adjustment universal 2 arm puller set with extremely narrow and extended legs

- Quick release function
- extremely pointed hook foot
- Ideal for confined spaces
- Long execution
- Uniform load distribution and centered tightening
- Through reversing the arms internal and external applications are possible
- Wide range of arms and hydraulic spindles available
- Extremely robust spindle with inductively hardened thread
- Special tool steel

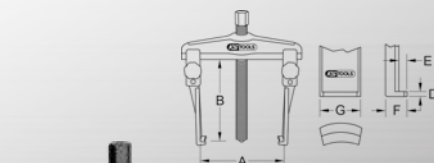

	A	B	C	max	mm	D	E	F	G	kg	€	
	mm	mm	mm	t	mm	mm	mm	mm	mm			
620.0034	20-90	120	70-130	3.5	M14x1.5 x 130	17	2	8	14	28	1,10	97,50
620.0035	20-90	200	70-130	3.5	M14x1.5 x 130	17	2	8	14	28	1,50	97,50
620.0036	20-90	250	70-130	3.5	M14x1.5 x 130	17	2	8	14	28	1,70	103,90
620.0037	25-130	120	80-180	3.5	M14x1.5 x 130	17	2	8	14	28	1,30	101,90
620.0038	25-130	200	80-180	3.5	M14x1.5 x 130	17	2	8	14	28	1,70	101,90
620.0039	25-130	250	80-180	3.5	M14x1.5 x 130	17	2	8	14	28	1,90	106,90

Quick adjustment universal 2 arm puller set with extremely narrow and extended legs

- Quick release function
- Narrow execution
- Long execution
- extremely pointed hook foot
- Ideal for confined spaces
- Uniform load distribution and centered tightening
- Through reversing the arms internal and external applications are possible
- Wide range of arms and hydraulic spindles available
- Extremely robust spindle with inductively hardened thread
- Special tool steel

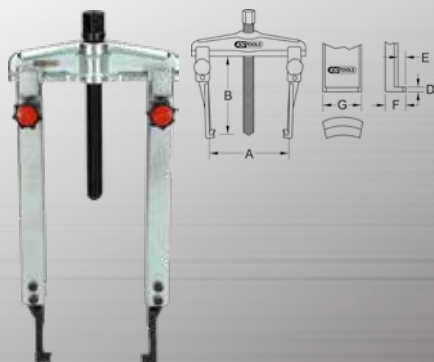

	A	B	C	max	mm	D	E	F	G	kg	€
	mm	mm	mm	t	mm	mm	mm	mm	mm		
620.0062	20-90	120	70-130	2.5	M14x1.5 x 130	17	3,6	8	14	1,10	102,90
620.0063	20-90	200	70-130	2.5	M14x1.5 x 130	17	3,6	8	14	1,50	102,90
620.0064	20-90	250	70-130	2.5	M14x1.5 x 130	17	3,6	8	14	1,70	108,50
620.0065	25-130	120	80-180	2.5	M14x1.5 x 130	17	3,6	8	14	1,30	105,90
620.0066	25-130	200	80-180	2.5	M14x1.5 x 130	17	3,6	8	14	1,70	105,90
620.0067	25-130	250	80-180	2.5	M14x1.5 x 130	17	3,6	8	14	1,90	112,50
620.0068	50-160	220	105-220	5.0	G1/2"x14 x 210	22	5	7,5	15	2,70	194,90
620.0069	50-160	300	105-220	5.0	G1/2"x14 x 210	22	5	7,5	15	2,70	194,90
620.0071	60-200	220	120-270	5.0	G1/2"x14 x 210	22	5	7,5	15	2,70	205,50
620.0072	60-200	300	120-270	5.0	G1/2"x14 x 210	22	5	7,5	15	2,70	206,50

Quick adjustment universal 2 arm puller set with narrow and extended legs

- Quick release function
- Ideal for confined spaces
- Long execution
- Uniform load distribution and centered tightening
- Through reversing the arms internal and external applications are possible
- Wide range of arms and hydraulic spindles available
- Extremely robust spindle with inductively hardened thread
- Special tool steel

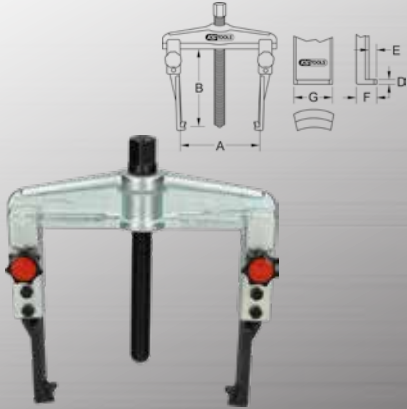

	A mm	B mm	C mm	max t	mm	D mm	E mm	F mm	G mm	kg	€	
620.0012	20-90	120	70-130	4,5	M14x1,5 x 130	17	3,6	8	14	28	1,10	97,50
620.0013	20-90	200	70-130	4,5	M14x1,5 x 130	17	3,6	8	14	28	1,50	97,50
620.0014	20-90	250	70-130	4,5	M14x1,5 x 130	17	3,6	8	14	28	1,70	102,90
620.0015	25-130	120	80-180	4,5	M14x1,5 x 130	17	3,6	8	14	28	1,30	100,50
620.0016	25-130	200	80-180	4,5	M14x1,5 x 130	17	3,6	8	14	28	1,70	101,90
620.0017	25-130	250	80-180	4,5	M14x1,5 x 130	17	3,6	8	14	28	1,90	106,90
620.0018	50-160	220	105-220	6,5	G1/2"x14 x 210	17	5	7,5	15	40	3,50	185,50
620.0019	50-160	300	105-220	6,5	G1/2"x14 x 210	17	5	7,5	15	40	4,00	185,50
620.0021	60-200	220	120-270	6,5	G1/2"x14 x 210	17	5	7,5	15	40	3,80	195,90
620.0022	60-200	300	120-270	6,5	G1/2"x14 x 210	17	5	7,5	15	40	4,30	196,90

UNIVERSAL 2 ARM PULLER SET

Universal puller set

- Through reversing the arms internal and external applications are possible
- Two armed traverse for 2 or 3 hooks
- Wide range of arms and hydraulic spindles available
- Extremely robust spindle with inductively hardened thread
- Special tool steel

Application range: Gear wheels, bearings, pinions, synchroniser hubs etc.

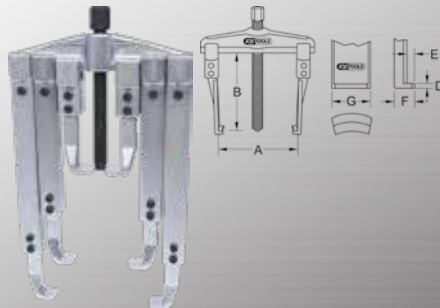

	A mm	B mm	max t	max N·m	mm	kg	€		
700.1320	8 pcs	120	260	4,5	80	M14 x 1,5x180	17	3,54	497,50

consists of:

	kg	€
700.1311	Spindle, M14x1,5	180
700.1312	Two armed traverse	485
700.1321	Draw-off arm, 120mm	260
700.1322	Draw-off arm, 230mm	540
700.1323	Draw-off arm, 280mm	640

Universal puller set

- Legs double ended usable
- Reception star for 2 or 3 hooks
- Extremely robust spindle with inductively hardened thread
- Special tool steel
- In durable plastic storage case



	kg	€	
700.1100	11 pcs Universal puller set	4,39	148,90

consists of:

	kg	
700.1120	Mechanical 2 and 3 leg puller, 4"	0,96
700.1130	Mechanical 2 and 3 leg puller, 6"	1,83
700.1140	Bearing splitter, for max. Ø 50 mm	1,15

Quick adjustment universal puller set

- Quick release function
- Ideal for confined spaces
- Through reversing the arms internal and external applications are possible
- Wide range of arms and hydraulic spindles available
- Extremely robust spindle with inductively hardened thread
- Special tool steel
- In durable plastic storage case



	A mm	B mm	max t	kg	€		
625.1701	7 pcs	20 - 90	100	M14 x 1,5	5,5	2,30	153,50

consists of:

	kg	€
620.1701	Quick release universal 2 arm puller	1,00
630.1701	Quick release 3 arm puller	1,30
980.1090	Special thread grease for puller and pusher spindles	0,01

Quick adjustment universal puller set

- Quick release function
- Ideal for confined spaces
- Through reversing the arms internal and external applications are possible
- Wide range of arms and hydraulic spindles available
- Extremely robust spindle with inductively hardened thread
- Special tool steel
- In durable plastic storage case



	A mm	B mm	max t	kg	€		
625.1703	7 pcs	50 - 160	150	G1/2"x14Gg	5,5	6,50	268,50

consists of:

	kg	€
620.1703	Quick release universal 2 arm puller, 50-160mm	3,00
630.1703	Quick release 3 arm puller, 50-160mm	3,50
980.1090	Special thread grease, tube	0,01

Hydraulic universal 2 + 3 arm puller set

- Less risk of slippage due to automatically closing pulling arm
- 8 length positions possible
- Extremely robust spindle with inductively hardened thread
- Lower power usage
- Special tool steel
- In durable plastic storage case



	kg	€	
700.1200	22 pcs Hydraulic universal 2 + 3 arm puller set	16,40	304,90

consists of:

		
700.1202	Puller legs, 4"	410
700.1203	Puller legs, 6"	600
700.1204	Puller legs, 8"	840
700.1205	Yoke f.2 legs, quickly modified	300
700.1206	Yoke f.3 legs, quickly modified	760
700.1207	Thrust bolt extension, 20 mm	50
700.1208	Thrust bolt extension, 35 mm	130
700.1209	Thrust bolt extension, 85 mm	320
700.1210	Pulling ring f.hydraulic thrust bolt	322
700.1220	Separator/puller tool, for max. Ø 105 mm	2540
700.1221	Yoke f.bearing separator tool	1480
700.1222	Extension f.bearing separator tool, 185mm	1060
700.1223	Spigot f.bearing separator tool, 235mm	1110
700.1400-1	Hydraulic spindle 10 t, AG 1.1/2"x16G	1344

Universal 2 + 3 arm puller set

- Slim hooks
- Ideal for confined spaces
- Uniform load distribution and centered tightening
- Through reversing the arms internal and external applications are possible
- Wide range of arms and hydraulic spindles available
- Extremely robust spindle with inductively hardened thread
- Excellent power transfer
- Special tool steel
- In durable plastic storage case



		€
700.1300 12 pcs Universal 2 + 3 arm puller set	6,69	298,50

consists of:

		
700.1311	Spindle, M14x1,5	180
700.1312	Two armed traverse	485
700.1313	Three armed traverse	675
700.1314	Draw-off arm, 100mm	250
700.1315	Draw-off arm, 210mm	530
700.1316	Draw-off arm, 260mm	640



UNIVERSAL 3 ARM PULLER

Universal 3 arm puller

- With tension screw for proportional tension force distribution
- Extremely robust spindle with inductively hardened thread
- Special tool steel



	A mm	B mm	max t mm	mm	D mm	E mm	F mm	G mm		€	
630.0015	10-60	45	2,5	M10x105	12	1	5	12	8	400	60,90
630.0016	15-70	65	3,0	M10x105	12	1	5	12	8	500	79,50
630.0017	20-100	80	3,5	M10x150	12	1,8	10	20	12	800	90,90

Universal 3 arm puller with slide hammer

- With tension screw for proportional tension force distribution
- Extremely robust spindle with inductively hardened thread
- Special tool steel



	A mm	B mm	max t mm	D mm	E mm	F mm	G mm		€
630.0018	10-60	45	2,5	1	5	12	8	1,30	100,50
630.0019	15-70	65	3,0	1	5	12	8	1,70	118,90
630.0021	20-100	80	3,5	1,8	10	20	12	2,00	118,90

Basic universal 3 arm puller

- Uniform load distribution and centered tightening
- Extremely robust spindle with inductively hardened thread
- Special tool steel

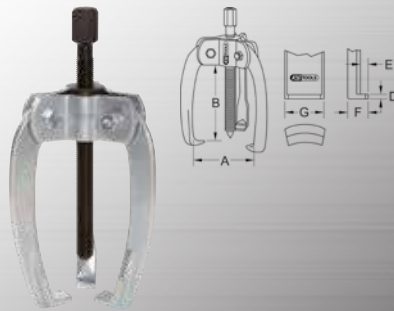

	A mm	B mm	max t mm	mm	D mm	E mm	F mm	G mm		€	
630.4301	10-100	80	2,5	M12x1,25 x 162	14	4	12	26	13	0,91	65,50
630.4302	10-120	120	3	M14x1,5 x 193	17	5	14	30	16	1,49	96,50
630.4303	20-160	160	3,5	M18x1,5 x 243	19	6	18	36	20	2,50	143,50
630.4304	20-200	200	4	M22x2 x 293	24	7	22	40	24	4,20	197,90

Universal 3 arm puller

- Legs double ended usable
- Extremely robust spindle with inductively hardened thread
- Special tool steel



	A mm	B mm	max t mm	mm	D mm	E mm	F mm	G mm		€	
630.3001	20-150	85	4	M14x1,5 x 130	17	2	9	21	12	1,20	67,50
630.3002	40-220	130	4,5	M18x1,5 x 240	19	4	11	25	21	2,90	129,50

Universal 3 arm puller

- Locking handle
- Uniform load distribution and centered tightening
- Ideally suited for extracting small parts
- Automatic pressure on the legs
- Extremely robust spindle with inductively hardened thread
- Special tool steel



	A mm	B mm	max t mm	mm	D mm	E mm	F mm	G mm		€	
630.4101	10-60	45	2,5	M10x1 x 90	12	2	9	18	10	300	49,50
630.4102	10-70	65	3	M10x1 x 110	12	2	9	18	10	300	49,50
630.4103	10-100	80	3,5	M12x1,25 x 140	14	2,3	12	25	13	800	52,50

3-jaw pole terminal extractor with t-bar

- 3-jaw
- Ideally suited for removing the battery pole terminal
- Locking handle
- Automatic pressure on the legs
- Extremely robust spindle with inductively hardened thread
- Screwed
- Sturdy hook
- Special tool steel

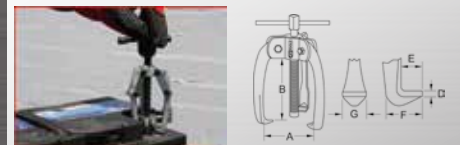

	A mm	B mm	max t mm	mm	D mm	E mm	F mm	G mm		€
700.1167	10-60	40	0,75	M10 x 60	2,3	5,5	12,3	10,0	181	46,50
700.1168	10-60	60	0,8	M10 x 80	3,0	5,5	12,5	10,0	215	52,50
700.1169	10-70	80	1,0	M10 x 100	3,0	8,0	15,2	14,1	323	54,50

Universal 3 arm puller

- Legs are adjustable in the working depth
- Uniform load distribution and centered tightening
- Extremely robust spindle with inductively hardened thread
- Special tool steel

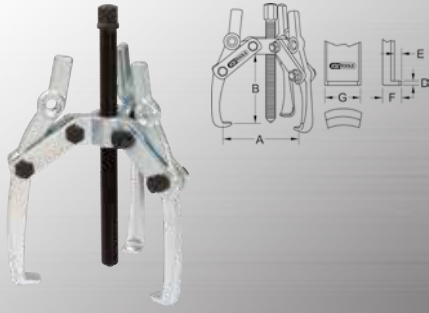

	A mm	B mm	max t	mm	D mm	E mm	F mm	G mm	kg	€
630.3401	20-170	130	4	M14x1,5 x 130	17	2	11	23	1,30	74,90
630.3402	20-230	200	4,5	M18x1,5 x 240	19	4,5	16	33	20	113,50

Hydraulic universal 3 arm puller

- Legs are adjustable in the working depth
- Uniform load distribution and centered tightening
- Through reversing the arms internal and external applications are possible
- Pulling hooks are automatically pressed against the part to be pulled off
- Different leg variants available
- Includes hydraulic thrust spindle
- Excellent power transfer
- Special tool steel

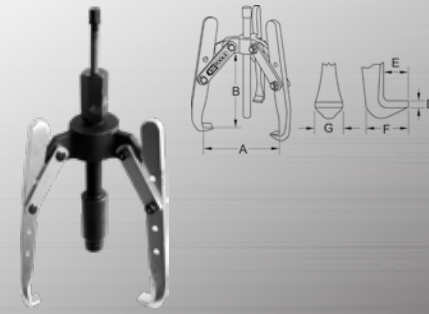

	A mm	B mm	C mm	max t	mm	D mm	E mm	F mm	G mm	kg	€	
630.0027	50-350	135	90-135	15	M11x1,5 x 100	17	5	25	48	30	12,50	674,50
630.0028	50-350	135	95-140	15	M11x1,5 x 100	17	5	25	48	30	13,50	699,90
630.0029	50-350	135	90-130	15	M11x1,5 x 100	17	5	25	48	30	14,00	769,50
630.0031	50-350	135	100-175	15	M11x1,5 x 100	17	5	25	48	30	14,50	786,50
630.0032	50-350	135	100-180	15	M11x1,5 x 100	17	5	25	48	30	15,00	829,50

Universal 3 arm puller

- Legs are adjustable in the working depth
- Uniform load distribution and centered tightening
- Hydraulic spindles available for thread G1/2"
- Extremely robust spindle with inductively hardened thread
- Special tool steel

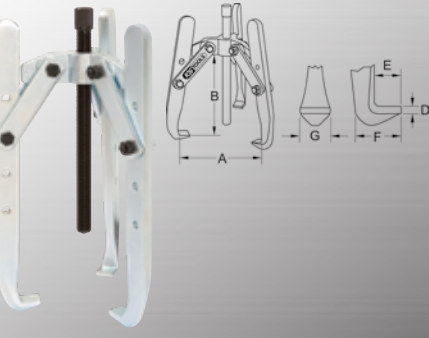

	A mm	B mm	max t	mm	D mm	E mm	F mm	G mm	kg	€	
630.3601	18-100	85	3	M10 x 105	12	2	10	20	14	0,50	53,50
630.3602	20-200	150	4	M14x1,5 x130	17	3	14	25	18	1,70	71,90
630.3603	35-250	220	4,5	M18x1,5 x240	19	4	20	36	25	3,90	118,90
630.3604	50-300	250	12	G1/2"x14g x 270	22	5	25	48	30	7,30	190,50
630.3605	50-350	350	12	G1/2"x14g x 270	22	5	25	48	30	8,30	218,50
630.3606	50-400	400	12	G1/2"x14g x 270	22	5	25	48	30	8,80	238,90
630.3607	50-450	450	12	G1/2"x14g x 270	22	5	25	48	30	9,40	258,90
630.3608	50-500	500	12	G1/2"x14g x 270	22	5	25	48	30	10,00	279,50
630.3609	50-500	650	12	G1/2"x14g x 270	22	5	25	48	30	11,60	322,50
630.3610	50-500	1000	12	G1/2"x14g x 270	22	5	25	48	30	16,00	420,50

Hydraulic universal 3 arm puller

- Legs are adjustable in the working depth
- Uniform load distribution and centered tightening
- Wide range of arms and hydraulic spindles available
- Includes hydraulic thrust spindle
- Excellent power transfer
- Special tool steel

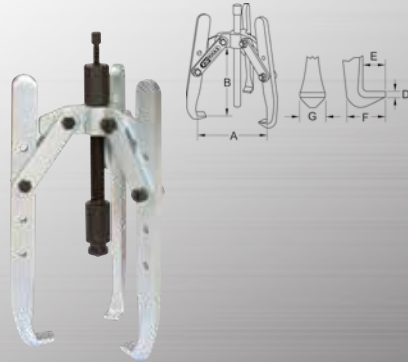

	A mm	B mm	max t	mm	D mm	E mm	F mm	G mm	kg	€	
630.3801	50-300	250	12	M14x1,5 x 100	17	5	25	48	30	12,50	373,50
630.3802	50-350	350	12	M14x1,5 x 100	17	5	25	48	30	13,50	402,50
630.3803	50-400	400	12	M14x1,5 x 100	17	5	25	48	30	14,00	421,50
630.3804	50-450	450	12	M14x1,5 x 100	17	5	25	48	30	14,50	442,90
630.3805	50-500	500	12	M14x1,5 x 100	17	5	25	48	30	15,00	463,50
630.3806	50-500	650	12	M14x1,5 x 100	17	5	25	48	30	16,60	506,50
630.3807	50-500	1000	12	M14x1,5 x 100	17	5	25	48	30	21,50	604,50

Universal puller 2 and 3 arm

- Legs double ended usable
- Reception star for 2 or 3 hooks
- Extremely robust spindle with inductively hardened thread
- Special tool steel



	A mm	B mm	max t	mm	D mm	E mm	F mm	G mm	kg	€	
700.1120	70	75	1,2	3/8"x24g x 120	13	3,2	8,4	20	8,4	960	28,90
700.1130	120	150	1,2	M14x1,25 x 175	16	7,2	7	17,8	7,0	1830	46,50

Universal 3 arm puller

- Uniform load distribution and centered tightening
- Through reversing the arms internal and external applications are possible
- Hydraulic spindles available for thread G1/2"
- Excellent power transfer
- Special tool steel



	A mm	B mm	C mm	max t	mm	D mm	E mm	F mm	G mm	kg	€	
630.0101	20-90	100	70-140	5,5	M14x1,5 x 130	17	3	13	25	20	1,30	99,50
630.0102	25-100	100	75-155	5,5	M14x1,5 x 130	17	3	13	25	20	1,50	105,90
630.0103	50-160	150	130-220	7	G1/2"x14g x 210	22	4	16	35	25	3,50	187,50
630.0104	50-200	150	130-255	7	G1/2"x14g x 210	22	4	16	35	25	4,00	205,50

Quick release 3 arm puller

- Quick release
- Ideal for confined spaces
- Uniform load distribution and centered tightening
- Through reversing the arms internal and external applications are possible
- Hydraulic spindles available for thread G1/2"
- Extremely robust spindle with inductively hardened thread
- Special tool steel

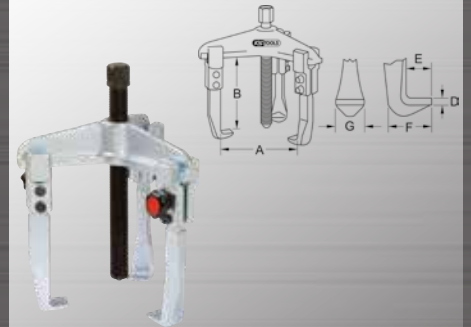

	A mm	B mm	C mm	max t	mm	D mm	E mm	F mm	G mm	kg	€	
630.1701	20-90	100	15-145	5,5	M14x1,5 x 130	17	3	13	25	20	1,30	99,50
630.1702	25-100	100	15-170	5,5	M14x1,5 x 130	17	3	13	25	20	1,50	105,90
630.1703	50-160	150	75-185	7	G1/2"x14g x 210	22	4	16	35	25	3,50	187,50
630.1704	60-200	150	85-225	7	G1/2"x14g x 210	22	4	16	35	25	4,00	205,50

Hydraulic universal 3 arm puller

- Uniform load distribution and centered tightening
- Through reversing the arms internal and external applications are possible
- Different leg variants available
- Includes hydraulic thrust spindle
- Excellent power transfer
- Special tool steel

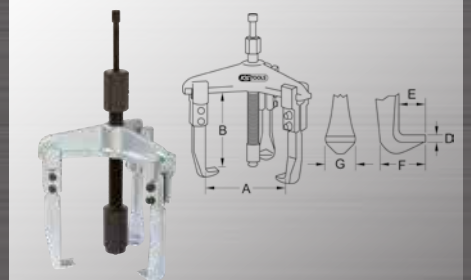

	A mm	B mm	C mm	max t	Hydraulic spindle	D mm	E mm	F mm	G mm	kg	€	
630.0301	50-160	145	125-215	12	615.0003	32	4	16	35	25	4,00	346,90
630.0302	60-200	145	150-255	12	615.0003	32	4	16	35	25	4,40	365,90

Hydraulic quick release universal 3 arm puller

- Quick release function
- Uniform load distribution and centered tightening
- Through reversing the arms internal and external applications are possible
- Different leg variants available
- Includes hydraulic thrust spindle
- Excellent power transfer
- Special tool steel

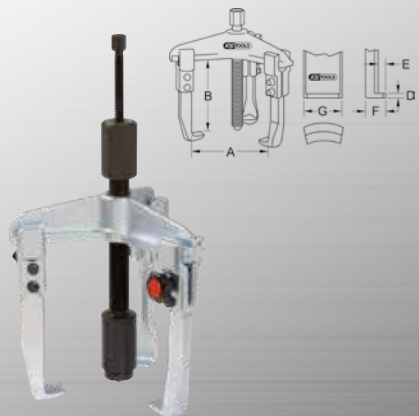

	A mm	B mm	C mm	max t	Hydraulic spindle mm	D mm	E mm	F mm	G mm	kg	€	
630.1901	50-100	145	75-145	12	615.0002	32	4	16	35	25	4,00	346,90
630.1902	50-200	145	135-255	12	615.0002	32	4	16	35	25	4,40	365,90

Universal 2 + 3 arm puller

- Legs double ended usable
- Through reversing the arms internal and external applications are possible
- Reception star for 2 or 3 hooks
- Extremely robust spindle with inductively hardened thread
- Special tool steel



	A mm	B mm	C mm	max t	mm	D mm	E mm	F mm	G mm	kg	€	
640.4203	60	65	90	2,0	G38"x 1,06x110	13	3	10	18	11	0,47	58,90
640.4204	90	100	130	5,0	G9"16"x 2,0px190	17	4	15,5	29	17	1,60	102,90
640.4205	165	170	170	7,0	G34"x 2,0px285	22	4	15,5	29	17	3,20	133,90

Universal 3 arm puller set with extremely narrow legs

- Narrow execution
- extremely pointed hook foot
- Ideal for confined spaces
- Uniform load distribution and centered tightening
- Through reversing the arms internal and external applications are possible
- Wide range of arms and hydraulic spindles available
- Extremely robust spindle with inductively hardened thread
- Special tool steel

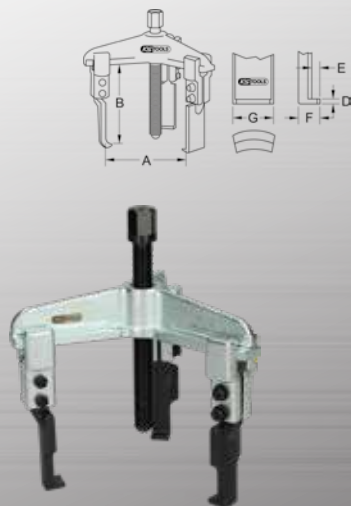

	A mm	B mm	C mm	max t	mm	D mm	E mm	F mm	G mm	kg	€	
630.0003	20-90	100	120-260	3	M14x1,5 x 130	17	8	14	14	14	1,30	116,90
630.0004	25-130	100	70-180	3	M14x1,5 x 130	17	8	14	14	14	1,50	144,50
630.0005	50-160	150	200-420	5	G1/2"x14 x 210	22	7,5	15	27	27	3,50	207,50
630.0006	60-200	150	110-270	5	G1/2"x14 x 210	22	7,5	15	27	27	4,00	216,50

Universal 3 arm puller set with narrow legs

- Ideal for confined spaces
- Uniform load distribution and centered tightening
- Through reversing the arms internal and external applications are possible
- Hydraulic spindles available for thread G1/2"
- Extremely robust spindle with inductively hardened thread
- Special tool steel

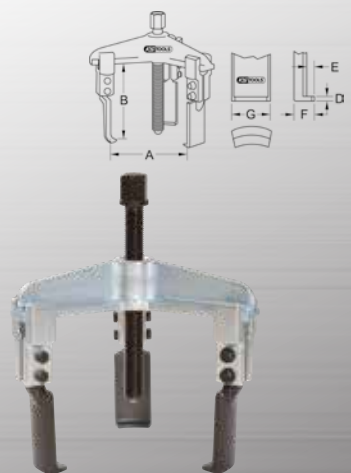

	A mm	B mm	C mm	max t	mm	D mm	E mm	F mm	G mm	kg	€	
630.0001	20-90	100	120-260	4	M14x1,5 x 130	17	2	8	14	28	1,30	99,50
630.0002	25-130	100	160-340	4	M14x1,5 x 130	17	2	8	14	28	1,50	125,50
630.0901	20-90	100	35-115	5	M14x1,5 x 130	17	3,6	6	13	27	1,30	129,50
630.0902	25-130	100	40-145	5	M14x1,5 x 130	17	3,6	6	13	27	1,50	135,90
630.0903	50-160	150	65-175	6,5	G12"x14 x 210	22	5	8	17	40	3,50	238,90
630.0904	60-200	150	120-230	6,5	G12"x14 x 210	22	5	8	17	40	4,00	256,90

Quick adjustment universal 3 arm puller set with extremely narrow legs

- Quick release function
- Narrow execution
- extremely pointed hook foot
- Ideal for confined spaces
- Uniform load distribution and centered tightening
- Through reversing the arms internal and external applications are possible
- Wide range of arms and hydraulic spindles available
- Extremely robust spindle with inductively hardened thread
- Special tool steel

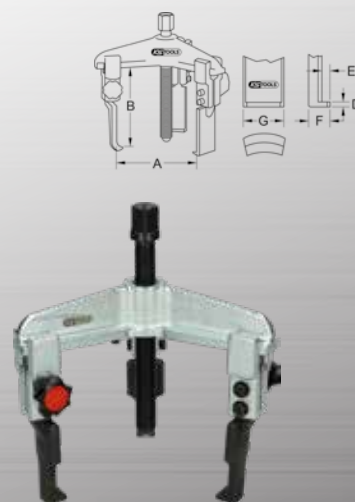

	A mm	B mm	C mm	max t	mm	D mm	E mm	F mm	G mm	kg	€	
630.0007	20-90	100	70-130	3	M14x1,5 x 130	17	3,6	14	14	14	1,30	124,50
630.0008	25-130	100	140-340	3	M14x1,5 x 130	17	3,6	14	14	14	1,50	150,90
630.0009	50-160	150	200-420	5	G1/2"x14 x 210	22	5	15	27	27	3,50	216,50
630.0011	60-200	150	120-260	5	G1/2"x14 x 210	22	5	15	27	27	4,00	222,50

Quick release 3 arm puller set with narrow legs

- Quick release
- Ideal for confined spaces
- Uniform load distribution and centered tightening
- Through reversing the arms internal and external applications are possible
- Hydraulic spindles available for thread G1/2"
- Extremely robust spindle with inductively hardened thread
- Special tool steel

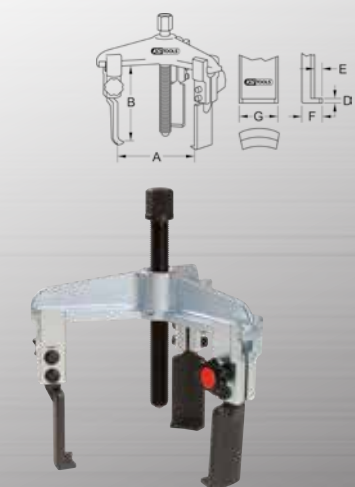

	A mm	B mm	C mm	max t	mm	D mm	E mm	F mm	G mm	kg	€	
630.1101	20-90	100	80-125	5	M14x1,5 x 130	17	3,6	6	13	27	1,30	129,50
630.1102	25-130	100	90-150	5	M14x1,5 x 130	17	3,6	6	13	27	1,50	135,90
630.1103	50-160	150	115-195	6,5	G12"x14 x 210	22	5	8	17	40	3,50	238,90
630.1104	60-200	150	115-215	6,5	G12"x14 x 210	22	5	8	17	40	4,00	256,90

UNIVERSAL 3 ARM PULLER SET

Universal puller set

- Legs double ended usable
- Reception star for 2 or 3 hooks
- Extremely robust spindle with inductively hardened thread
- Special tool steel
- In durable plastic storage case



			kg	€
700.1100	11 pcs	Universal puller set	4,39	148,90

consists of:

		kg
700.1120	Mechanical 2 and 3 leg puller, 4"	0,96
700.1130	Mechanical 2 and 3 leg puller, 6"	1,83
700.1140	Bearing splitter, for max. Ø 50 mm	1,15

Quick adjustment universal puller set

- Quick release function
- Ideal for confined spaces
- Through reversing the arms internal and external applications are possible
- Wide range of arms and hydraulic spindles available
- Extremely robust spindle with inductively hardened thread
- Special tool steel
- In durable plastic storage case



	A mm	B mm	mm	max t	kg	€	
625.1701	7 pcs	20 - 90	100	M14 x 1,5	5,5	2,30	153,50

consists of:

		kg
620.1701	Quick release universal 2 arm puller, 20-90mm	1,00
630.1701	Quick release 3 arm puller, 20-90mm	1,30
980.1090	Special thread grease, tube	0,01

Quick adjustment universal puller set

- Quick release function
- Ideal for confined spaces
- Through reversing the arms internal and external applications are possible
- Wide range of arms and hydraulic spindles available
- Extremely robust spindle with inductively hardened thread
- Special tool steel
- In durable plastic storage case



	A mm	B mm	mm	max t	kg	€	
625.1703	7 pcs	50 - 160	150	G1/2"x14Gg	5,5	6,50	268,50

consists of:

		kg
620.1703	Quick release universal 2 arm puller, 50-160mm	3,00
630.1703	Quick release 3 arm puller, 50-160mm	3,50
980.1090	Special thread grease, tube	0,01

Hydraulic universal 2 + 3 arm puller set

- Less risk of slippage due to automatically closing pulling arm
- 8 length positions possible
- Extremely robust spindle with inductively hardened thread
- Lower power usage
- Special tool steel
- In durable plastic storage case



		kg	€
700.1200	22 pcs Hydraulic universal 2 + 3 arm puller set	16,40	304,90

consists of:

		kg
700.1202	Puller legs, 4"	410
700.1203	Puller legs, 6"	600
700.1204	Puller legs, 8"	840
700.1205	Yoke f.2 legs, quickly modified	300
700.1206	Yoke f.3 legs, quickly modified	760
700.1207	Thrust bolt extension, 20 mm	50
700.1208	Thrust bolt extension, 35 mm	130
700.1209	Thrust bolt extension, 85 mm	320
700.1210	Pulling ring f.hydraulic thrust bolt	322
700.1220	Separator/puller tool, for max. Ø 105 mm	2540
700.1221	Yoke f.bearing separator tool	1480
700.1222	Extension f.bearing separator tool, 185mm	1060
700.1223	Spigot f.bearing separator tool, 235mm	1110
700.1400-1	Hydraulic spindle 10 t, AG 1.1/2"x16G	1344

Universal 2 + 3 arm puller set

- Slim hooks
- Ideal for confined spaces
- Uniform load distribution and centered tightening
- Through reversing the arms internal and external applications are possible
- Wide range of arms and hydraulic spindles available
- Extremely robust spindle with inductively hardened thread
- Excellent power transfer
- Special tool steel
- In durable plastic storage case



		kg	€
700.1300	12 pcs Universal 2 + 3 arm puller set	6,69	298,50

consists of:

		kg
700.1311	Spindle, M14x1,5	180
700.1312	Two armed traverse	485
700.1313	Three armed traverse	675
700.1314	Draw-off arm, 100mm	250
700.1315	Draw-off arm, 210mm	530
700.1316	Draw-off arm, 260mm	640



SEPARATOR PULLER TOOL

Separator puller tool

- To be used with separately available separator device
- For the removal of secure bearings and bushes
- Extremely robust spindle with inductively hardened thread
- Special tool steel

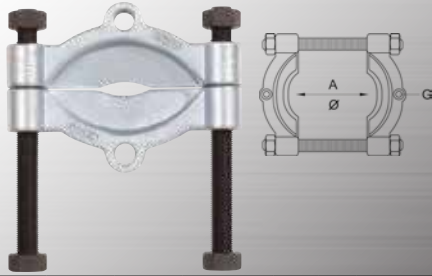

	A mm	G	mm	mm	kg	€
605.0501	5-60	M12	M10 x 120	17	0,40	57,90
605.0502	12-75	M12	M12 x 140	19	0,70	78,50
605.0503	22-115	M16	M16 x 200	24	1,90	114,50
605.0504	25-155	M20	M20 x 250	30	4,20	202,50
605.0505	30-220	M20	M24 x 410	36	12,00	410,90
605.0506	40-280	M24	M30 x 500	41	15,80	709,50

Yoke for bearing separator tool

- For use with the separator
- The train bolts are screwed into the threads of the separator
- Extremely robust spindle with inductively hardened thread
- Hydraulic thrust spindle available
- Special tool steel

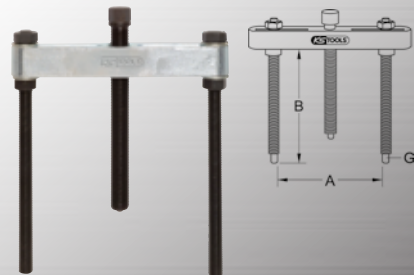

	A mm	B mm	G	max t	mm	mm	kg	€
605.0111	40-115	150	M12	2	M14x1,5 x 130	17	0,80	54,50
605.0112	45-140	150	M12	2,5	M14x1,5 x 130	17	1,10	87,90
605.0113	55-205	210	M16	4	G1/2"x14g x 210	22	2,70	130,50
605.0114	90-260	315	M20	5	G1/2"x14g x 210	22	5,20	206,50
605.0115	100-360	305	M20	7	G3/4"x14g x 280	27	8,80	413,50
605.0116	140-435	320	M24	13	G1"x11g x 370	36	16,70	651,90

Hydraulic thrust bolt with yoke for bearing separator tool

- For use with the separator
- The train bolts are screwed into the threads of the separator
- Includes hydraulic thrust spindle
- Excellent power transfer
- Special tool steel

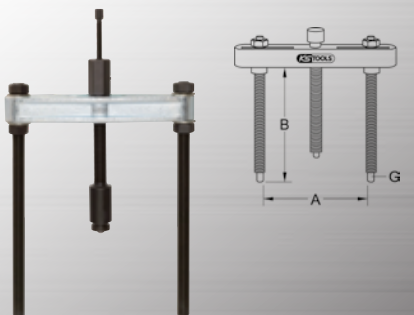

	A mm	B mm	G	max t	mm	mm	Hydraulic spindle	mm	kg	€
605.0301	55-205	135	M16	12	M16 x 280	615.0002	32	3,20	361,90	
605.0302	90-260	240	M20	12	M20x1,5 x 370	615.0002	32	5,70	437,90	
605.0303	100-360	230	M20	12	M20x1,5 x 370	615.0003	36	9,10	684,90	
605.0304	140-435	230	M24	15	M24x1,5 x 460	615.0004	41	17,60	943,90	

SEPARATOR PULLER TOOL SET

Separator set inclusive with yoke ø 5,0 - 60,0 mm

- For the removal of secure bearings and bushes
- Extremely robust spindle with inductively hardened thread
- Special tool steel
- In durable plastic storage case



			kg	€
605.0001	3 pcs	Separator set inclusive with yoke ø 5,0 - 60,0 mm	1,90	173,50

consists of:

		kg
605.0501	Bearing separator, 5-60mm	0,40
605.0111	Yoke for bearing separator tool, 40-115mm	0,80
605.0401	Extension for pull rod M12 x100mm	0,20

Separator set inclusive with yoke ø 12,0 - 75,0 mm

- For the removal of secure bearings and bushes
- Extremely robust spindle with inductively hardened thread
- Special tool steel
- In durable plastic storage case



			kg	€
605.0002	3 pcs	Separator set inclusive with yoke ø 12,0 - 75,0 mm	2,40	232,50

consists of:

		kg
605.0502	Separator puller tool, 12-75mm	0,70
605.0112	Yoke for bearing separator tool, 45-140mm	1,10
605.0402	Extension for pressure rod, M12 x100mm	0,20

Separator set inclusive with yoke ø 22,0 - 115,0 mm

- For the removal of secure bearings and bushes
- Extremely robust spindle with inductively hardened thread
- Hydraulic thrust spindle available
- Special tool steel
- In durable plastic storage case



			kg	€
605.0003	3 pcs	Separator set inclusive with yoke ø 22,0 - 115,0 mm	6,10	339,50

consists of:

		kg
605.0503	Separator puller tool, 22-115mm	1,90
605.0113	Yoke for bearing separator tool, 55-205mm	2,70
605.0403	Extension for pressure rod, M16 x100mm	0,40

Separator set inclusive with yoke ø 25,0 - 155,0 mm

- For the removal of secure bearings and bushes
- Extremely robust spindle with inductively hardened thread
- Hydraulic thrust spindle available
- Special tool steel
- In durable plastic storage case



			kg	€
605.0004	3 pcs	Separator set inclusive with yoke ø 25,0 - 155,0 mm	11,48	499,90

consists of:

		kg
605.0504	Separator puller tool, 25-155mm	4,20
605.0114	Yoke for bearing separator tool, 90-260mm	5,20
605.0404	Extension for pull rod, M20 x 1,5 x 100mm	0,70

Separator set inclusive with yoke ø 30,0 - 220,0 mm

- For the removal of secure bearings and bushes
- Extremely robust spindle with inductively hardened thread
- Hydraulic thrust spindle available
- Special tool steel
- In durable steel storage case



				€
605.0005	3 pcs	Separator set inclusive with yoke ø 30,0 - 220,0 mm	29,00	1139,50

consists of:

				€
605.0505		Separator puller tool, 30-220mm	12,00	
605.0115		Yoke for bearing separator tool, 100-360mm	8,80	
605.0405		Extension for pull rod, M20 x 1,5 x 100mm	0,70	

UNIVERSAL 3 ARM PULLER, HEAVY EXECUTION

Universal 3 arm puller

- extremely robust design
- Uniform load distribution and centered tightening
- Through reversing the arms internal and external applications are possible
- Wide range of arms and hydraulic spindles available
- Extremely robust spindle with inductively hardened thread
- Special tool steel

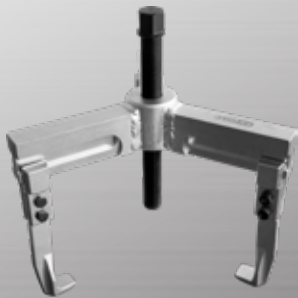
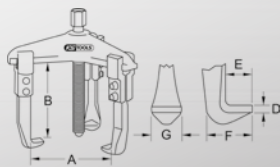

	A	B	C	max		D	E	F	G		€	
	mm	mm	mm	t	mm	mm	mm	mm	mm			
630.0012	100-380	200	210-410	15	G1"x11 x 310	36	5	25	54	35	21,00	924,50
630.0013	120-520	200	215-450	15	G1"x11 x 310	36	5	25	54	35	25,00	1014,50
630.0014	120-650	200	215-500	15	G1"x11 x 310	36	5	25	54	35	27,00	1053,90

Universal 3 arm puller, heavy execution

- extremely robust design for extreme loads
- Uniform load distribution and centered tightening
- Through reversing the arms internal and external applications are possible
- Different leg variants available
- Includes hydraulic thrust spindle
- Lower power usage
- Special tool steel

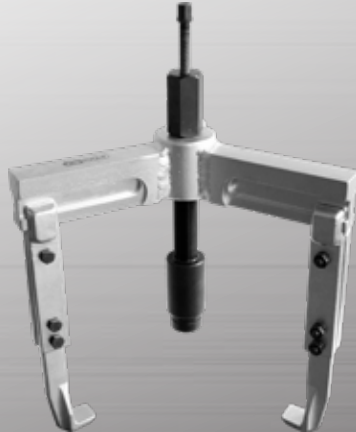
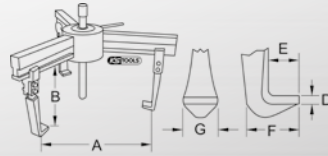

	A	B	C	max		D	E	F	G		€	
	mm	mm	mm	t	mm	mm	mm	mm	mm			
630.0023	100-380	185	240-410	15	M14x1,5 x 100	17	5	25	54	35	22,00	1286,50
630.0024	120-520	185	250-450	15	M14x1,5 x 100	17	5	25	54	35	26,30	1394,50
630.0025	120-650	185	250-500	15	M14x1,5 x 100	17	5	25	54	35	28,00	1451,90

Universal 3 arm puller

- Uniform load distribution and centered tightening
- Through reversing the arms internal and external applications are possible
- Draw off arms radial revolving
- Wide range of arms and hydraulic spindles available
- Extremely robust spindle with inductively hardened thread
- Special tool steel

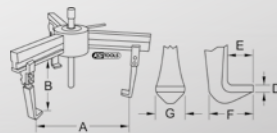

	A	B	C	max		D	E	F	G		€	
	mm	mm	mm	t	mm	mm	mm	mm	mm			
630.2301	150-700	200	250-650	15	G1"x11g x 370	36	10	33	55	50	42,50	1552,50

Universal 3 arm puller for using with hydraulic cylinder

- Consists of traverse and legs
- Traverse arm radial revolving and interchangeable
- Uniform load distribution and centered tightening
- Without hydraulic compression spindle / without hydraulic cylinder
- Without hydraulic pump
- Special tool steel

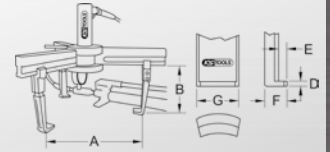

	A	B	C	max		D	E	F	G		€	
	mm	mm	mm	t	mm	mm	mm	mm	mm			
640.2315	150-700	200			M68x2	15	10	33	55	50	38,00	1429,50
640.2317	150-700	200			G1"x11g	17	10	33	55	50	40,00	1389,90

Universal 3 arm puller, heavy execution

- extremely robust design for extreme loads
- Uniform load distribution and centered tightening
- Through reversing the arms internal and external applications are possible
- Different leg variants available
- Includes hydraulic thrust spindle
- Lower power usage
- Special tool steel

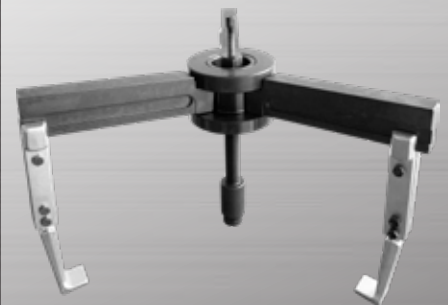
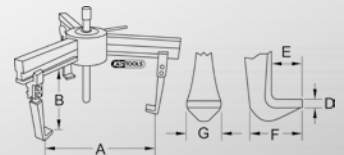

	A	B	C	max		D	E	F	G		€	
	mm	mm	mm	t	mm	mm	mm	mm	mm			
630.0026	150-700	275	500-720	15	M14x1,5 x 100	17	10	33	55	50	47,60	2106,90

HYDRAULIC PULLERS AND PUMP

Universal 2 arm puller for using with hydraulic cylinder

- Consists of traverse and legs
- Through reversing the arms internal and external applications are possible
- Without hydraulic compression spindle / without hydraulic cylinder
- Without hydraulic pump
- Special tool steel



	A mm	B mm	max t	D mm	E mm	F mm	G mm	kg	€
640.0210	640	225	10	10	33	55	50	20,00	806,90
640.0215	640	225	15	10	33	55	50	20,00	806,90
640.0217	640	225	17	10	33	55	50	21,50	873,50

Universal 2 arm puller for using with hydraulic cylinder

- Consists of traverse and legs
- Through reversing the arms internal and external applications are possible
- Without hydraulic compression spindle / without hydraulic cylinder
- Without hydraulic pump
- Special tool steel

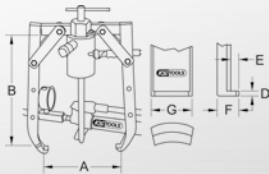

	A mm	B mm	max t	D mm	E mm	F mm	G mm	kg	€
640.0220	420	290	20	17	16	32	32	11,50	773,90
640.0230	700	400	30	24	23	48	40	20,00	1220,90
640.0250	1000	700	50	35	42	87	50	50,00	2238,50

Universal 3 arm puller for using with hydraulic cylinder

- Consists of traverse and legs
- Legs are adjustable in the working depth
- Uniform load distribution and centered tightening
- Without hydraulic compression spindle / without hydraulic cylinder
- Without hydraulic pump
- Special tool steel

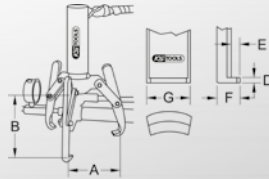

	A mm	B mm	mm	max t	D mm	E mm	F mm	G mm	kg	€
640.0310	350	250	UNC2.1/4" x 14	10	5	25	48	30	9,50	278,50
640.0315	350	250	M68 x 2	15	5	25	48	30	7,50	278,50
640.0317	350	250	G 1"x11g	17	5	25	48	30	8,50	265,50

Universal 3 arm puller for using with hydraulic cylinder

- Consists of traverse and legs
- Legs are adjustable in the working depth
- Uniform load distribution and centered tightening
- Without hydraulic compression spindle / without hydraulic cylinder
- Without hydraulic pump
- Special tool steel

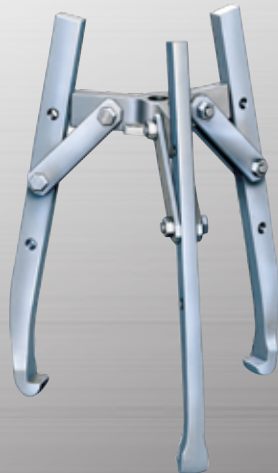
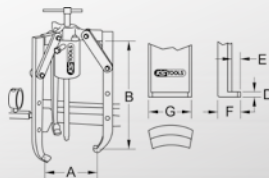

	A mm	B mm	max t	D mm	E mm	F mm	G mm	kg	€
640.0320	420	290	20	17	16	32	32	17,00	1066,90
640.0330	700	400	30	24	23	48	40	30,00	1785,90
640.0350	1000	700	50	35	42	87	50	70,00	3395,50

Hydraulic universal 3 arm puller

- Consists of traverse and legs
- Legs are adjustable in the working depth
- Traverse arm radial revolving and interchangeable
- Uniform load distribution and centered tightening
- Without hydraulic compression spindle / without hydraulic cylinder
- Without hydraulic pump
- Special tool steel

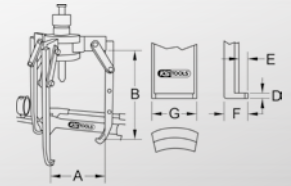

	A mm	B mm	mm	max t	D mm	E mm	F mm	G mm	kg	€
640.2415	500	440	M68x2	15	17	16	32	32	22,00	1698,50
640.2417	500	440	G1"x11g	17	17	16	32	32	24,00	1637,50

Universal 3 arm puller for using with hydraulic cylinder

- Consists of traverse and legs
- Traverse arm radial revolving and interchangeable
- Legs are adjustable in the working depth
- Uniform load distribution and centered tightening
- Without hydraulic compression spindle / without hydraulic cylinder
- Without hydraulic pump
- Special tool steel

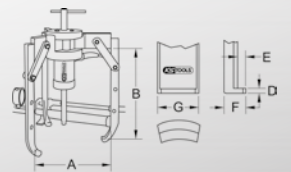

	A mm	B mm	max t	D mm	E mm	F mm	G mm	kg	€
640.2420	500	270	20	17	16	32	32	27,00	1703,50
640.2430	750	310	30	24	23	48	40	26,00	2388,50
640.2450	1000	660	50	35	42	87	50	106,00	4174,50

STRUCTURE OF A PULLER

Quick-clamp device

- The quick-clamping device enables tool-free and secure clamping of the arms by hand
- to move - loosen the knurled thumb screws

Hook with stepping

- Hooks can be moved by loosening the upper quick-clamping device

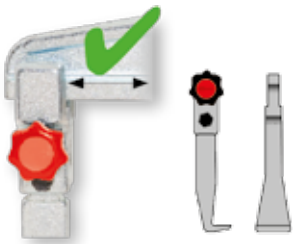

Standard hook without stepping

- Movement of the hooks by loosening the upper fast-action nut not possible. Here the fast-action nuts and lower nuts need to be loosened.

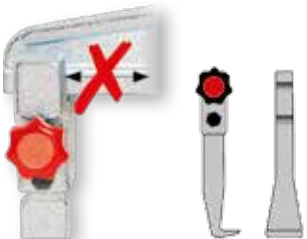

Traverse

- Traverse formed from quenched and tempered steel
- precision-milled guides
- designed for the highest stress

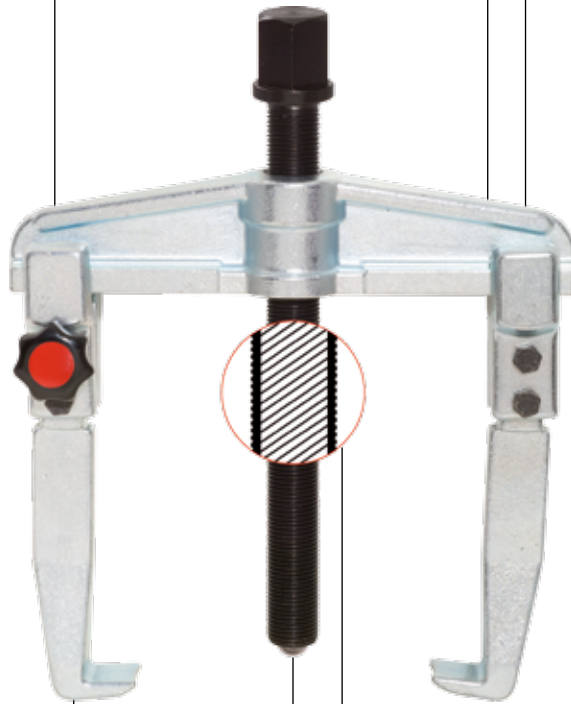

Two-screw quick-clamp device

- Using the fixing screws the hooks are braced securely on the traverse. The lower screw forms a positive connection of the adjustable block with the hooks. The upper screw clamps the adjustable block on the traverse.

Hook with stepping

- Hooks can be moved by loosening the upper nut

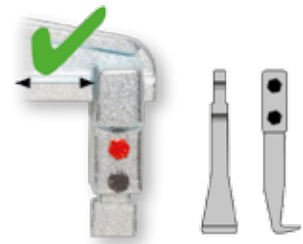

Standard hook without stepping

- Movement of the hooks by loosening the upper fast-action nut not possible. Here both nuts must be loosened.

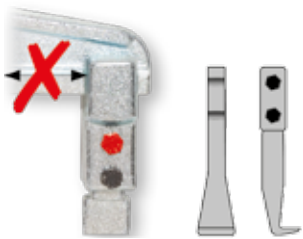

Universal hooks

- Formed from quenched and tempered steel and functional surfaces are precision-milled
- positive and force-closed connection between traverse hooks

Spindle

- Turned from quenched and tempered steel
- the thread is rolled and thus has a high stability and precision
- especially wear-resistant, case-hardened spindles, from G1/2" all spindles inductively hardened
- Hex drive with anti-slip device (collar)

Different pressure peaks

Differences after few work cycles

Spindle with ball



- No wear recognisable
- central pressing of the spindle continues to be guaranteed

Spindle with live centre



- Jamming in the spindle body
- Deformation of the dead centre
- Pressing the spindle centrally is no longer possible
- Replacement of the spindle required



COMBINATION OPTIONS FOR STANDARD / BAR PULLER

Mechanical spindle

Hydraulic spindle

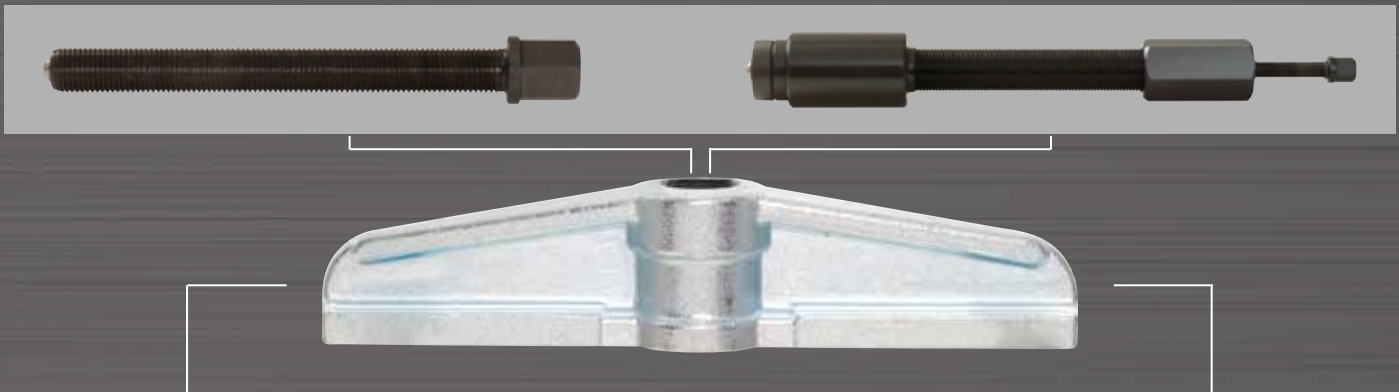

Hooks with quick-clamping device

Hooks with two-screw clamping device



Quick-clamping hooks	
Hook No.	for Puller
615.1001	620.1101 / 620.1102 630.1101 / 630.1102
615.1002	620.1101 / 620.1102 630.1101 / 630.1102
615.1003	620.1101 / 620.1102 630.1101 / 630.1102
615.1004	620.1101 / 620.1102 630.1101 / 630.1102
615.1005	620.1101 / 620.1102 630.1101 / 630.1102
615.1006	620.1101 / 620.1102 630.1101 / 630.1102
615.1007	620.1103 / 620.1104 630.1103 / 630.1104
615.1008	620.1103 / 620.1104 630.1103 / 630.1104
615.1009	620.1103 / 620.1104 630.1103 / 630.1104
615.1101	620.1701 / 620.1702 630.1701 / 630.1702
615.1102	620.1703 / 620.1704 630.1703 / 630.1704
615.1103	620.1705 / 620.1706 630.1903 / 630.1904

Two-screw clamp hooks					
Hook No.	for Puller	Hook No.	for Puller	Hook No.	for Puller
615.0101	620.0101 / 620.0102 630.0101 / 630.0102	615.0503	620.0105 / 620.0106 620.0107 620.0505 / 620.0506 620.0507 620.0703 / 620.0704 620.0705	615.0508	620.0108 630.2301 640.0210 / 640.0215 640.0217 640.2315 / 640.2317
615.0103	620.0105 / 620.0106 620.0107 620.0303 / 620.0304 620.0305 / 620.0306	615.0505	620.0105 / 620.0106 620.0107 620.0511 / 620.0512 620.0513 620.0709 / 620.0710 620.0711	615.0902	620.0901 / 620.0902 630.0901 / 630.0902
615.0501	620.0101 / 620.0102 620.0103 / 620.0104 620.0301 / 620.0302 620.0501 / 620.0502 630.0101 / 630.0102 630.0103 / 630.0104 630.0301 / 630.0302	615.0507	620.0108 630.2301 640.0210 / 640.0215 640.0217 640.2315 / 640.2317	615.0904	620.0103 / 620.0104 620.0903 / 620.0904 630.0903 / 630.0904
615.0501	620.0101 / 620.0102 620.0103 / 620.0104 620.0301 / 620.0302 620.0501 / 620.0502 630.0101 / 630.0102 630.0103 / 630.0104 630.0301 / 630.0302	615.0506	620.0108 630.2301 640.0210 / 640.0215 640.0217 640.2315 / 640.2317	615.0906	620.0103 / 620.0104 620.0903 / 620.0904 630.0903 / 630.0904
615.0501	620.0101 / 620.0102 620.0103 / 620.0104 620.0301 / 620.0302 620.0501 / 620.0502 630.0101 / 630.0102 630.0103 / 630.0104 630.0301 / 630.0302	615.0506	620.0108 630.2301 640.0210 / 640.0215 640.0217 640.2315 / 640.2317	615.0908	620.0101 / 620.0102 620.0901 / 620.0902 630.0901 / 630.0902

Caution: The hooks marked in red are not the original hooks relating to the pullers indicated, but can be used in these.

ACCESSORIES

Quick adjustment puller legs

- Quick release function
- For 2 arm and 3 arm pullers
- Special tool steel

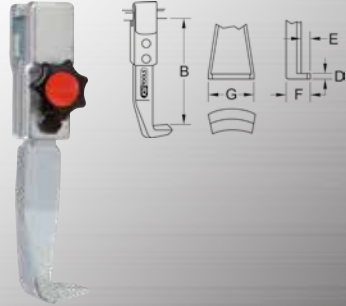

	B mm	D mm	E mm	F mm	G mm	Wt. g	€
615.1101	100	3	13	25	20	200	20,50
615.1102	150	4	16	35	25	700	36,50
615.1103	200	3	13	25	20	500	27,90

Puller legs, extremely narrow design

- Ideal for confined spaces
- For 2 arm and 3 arm pullers
- Special tool steel



	B mm	D mm	E mm	F mm	G mm	Wt. g	€
615.1011	100	3,6	8,0	14	14	250	41,90
615.1012	120	3,6	8,0	14	14	300	47,50
615.1013	200	3,6	8,0	14	14	500	47,50
615.1014	250	3,6	8,0	14	14	600	74,90
615.1015	150	5,0	7,5	15	27	600	53,50
615.1016	220	5,0	7,5	15	27	650	66,50
615.1017	300	5,0	7,5	15	27	1100	66,50

Puller legs, narrow design

- Ideal for confined spaces
- For 2 arm and 3 arm pullers
- Special tool steel

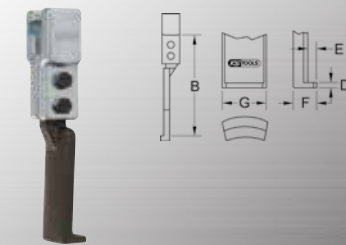

	B mm	D mm	E mm	F mm	G mm	Wt. g	€
615.0901	100	3,6	6	13	27	200	28,90
615.1031	120	3,6	8	14	28	280	33,50
615.0902	200	3,6	6	13	27	500	36,50
615.0903	250	3,6	6	13	27	600	40,90
615.0904	100	2	6	13	27	200	34,50
615.0905	200	2	6	13	27	500	43,90
615.0906	250	2	6	13	27	1100	46,50
615.0907	150	5	8	17	40	600	51,50
615.0908	220	5	8	17	40	800	62,50
615.0909	300	5	8	17	40	1800	64,50

Quick adjustment puller legs, extremely narrow design

- Quick release function
- Ideal for confined spaces
- For 2 arm and 3 arm pullers
- Special tool steel

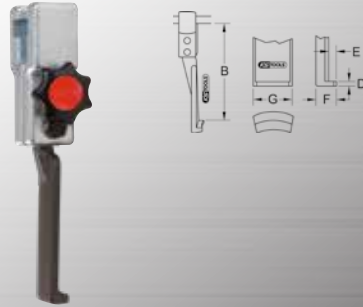

	B mm	D mm	E mm	F mm	G mm	Wt. g	€
615.1021	100	3,6	8	14	14	250	43,90
615.1022	120	3,6	8	14	14	300	49,50
615.1023	200	3,6	8	14	14	500	50,50
615.1024	250	3,6	8	14	14	600	52,50
615.1025	150	5,0	7,5	15	27	600	53,50
615.1026	220	5,0	7,5	15	27	650	66,50
615.1027	300	5,0	7,5	15	27	1100	66,50

Quick adjustment puller legs, narrow design

- Quick release function
- Ideal for confined spaces
- For 2 arm and 3 arm pullers
- Special tool steel



	B mm	D mm	E mm	F mm	G mm	Wt. g	€
615.1001	100	3,6	6	13	27	250	31,50
615.1041	120	3,6	8	14	28	300	49,50
615.1002	200	3,6	6	13	27	500	37,50
615.1003	250	3,6	6	13	27	600	42,90
615.1004	100	2,0	6	13	27	250	31,50
615.1005	200	2,0	6	13	27	500	38,50
615.1006	250	2,0	6	13	27	600	43,90
615.1007	150	5,0	8	17	40	650	53,50
615.1008	220	5,0	8	17	40	900	64,50
615.1009	300	5,0	8	17	40	1100	67,50

Pair of puller legs

- Legs are adjustable in the working depth
- for 2-arm pullers
- Special tool steel

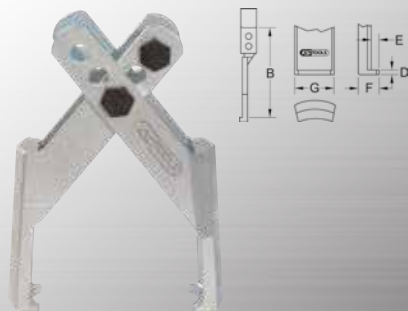

	For pullers	B mm	D mm	E mm	F mm	G mm	Wt. g	€
615.5201	620.5201	70-85	2,5	4,5	8,5	23	180	68,50
615.5202	620.5202	85-120	3,5	5	10	31	450	73,90
615.5203	620.5203	125-155	3,5	5	10	31	550	92,50

Pair of puller legs, narrow design

- Legs are adjustable in the working depth
- for 2-arm pullers
- Ideal for confined spaces
- Special tool steel

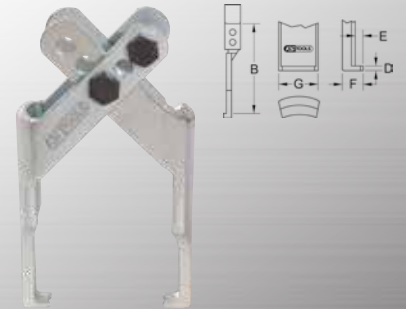

	For pullers	B mm	D mm	E mm	F mm	G mm	Wt. g	€
615.5301	620.5301	70-85	2,5	4,5	8,5	11	150	73,90
615.5302	620.5302	85-120	3,5	5	11	12	500	124,50

Puller legs

- For puller legs with quick adjustment
- Prevents slipping
- Special tool steel

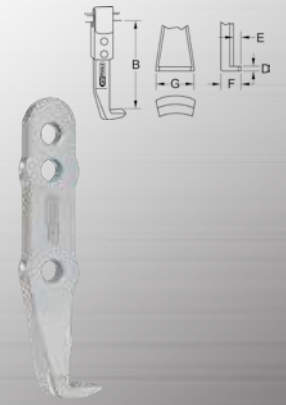

	For pullers	B mm	D mm	E mm	F mm	G mm	Wt. g	€
615.5401	620.5401	90	3	12	26	24	260	27,90
615.5402	620.5402	110	3	14	25	24	320	34,50
615.5403	620.5403	150	3	14	25	24	420	47,50

Puller legs with clamping yoke

- For 2 arm pullers with quick adjustment
- Legs are adjustable in the working depth
- Legs double ended usable
- Special tool steel

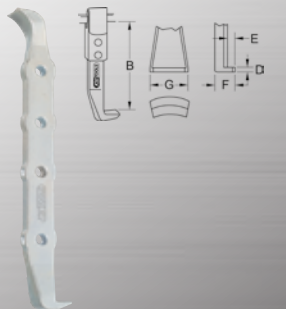

	For pullers	B mm	D mm	E mm	F mm	G mm	Wt. g	€
615.5501	620.5501	170	3	12	25	24	530	47,50
615.5502	620.5502	270	3	14	25	24	800	59,90
615.5503	620.5503	330	3	14	25	24	850	71,90

Puller legs double ended usable

- Legs double ended usable
- For 2 arm and 3 arm pullers
- Special tool steel



For pullers		B mm	D mm	E mm	F mm	G mm	kg	€
615.3001	620.3001+630.3001	85	2	9	21	12	100	21,50
615.3002	620.3002+630.3002	130	4	11	25	21	320	29,90

Puller legs

- Legs are adjustable in the working depth
- For 2 arm and 3 arm pullers
- Special tool steel

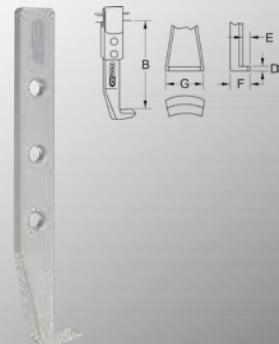

For pullers		B mm	D mm	E mm	F mm	G mm	kg	€
615.3601	620.3601+630.3601	85	3	14	25	18	100	14,90
615.3602	620.3602+630.3602	150	4	20	36	25	260	21,50
615.3603	620.3603+630.3603	220	5	25	48	30	650	29,90
615.3604	620.3604+630.3604	250	5	25	48	30	1200	49,50
615.3605	620.3605+630.3605	350	5	25	48	30	1600	53,50
615.3606	620.3606+630.3606	400	5	25	48	30	1800	58,90
615.3607	620.3607+630.3607	450	5	25	48	30	2000	69,50
615.3608	620.3608+630.3608	500	5	25	48	30	2200	81,50
615.3609	620.3609+630.3609	650	5	25	48	30	2800	93,50
615.3610	620.3610+630.3610	1000	5	25	48	30	4200	151,90



Puller legs

- For 2 arm and 3 arm hydraulic pullers
- Special tool steel



For pullers		B mm	D mm	E mm	F mm	G mm	kg	€
645.0251	640.0210-17+640.2315-17	225	10	33	55	50	2,10	110,50
645.0252	640.0210-17+640.2315-17	300	10	33	55	50	3,00	145,50
645.0253	640.0210-17+640.2315-17	400	10	33	55	50	3,70	169,50
645.0254	640.0210-17+640.2315-17	500	10	33	55	50	4,40	204,50
645.0261	640.0220	290	17	16	32	32	3,30	192,50
645.0262	640.0230	400	24	23	48	40	6,50	270,90
645.0263	640.0250	700	35	42	87	50	17,00	604,50
645.0351	640.0310-17	250	5	25	48	30	1,80	47,50
645.0352	640.0310-17	350	5	25	48	30	1,90	53,50
645.0353	640.0310-17	400	5	25	48	30	2,00	58,90
645.0354	640.0310-17	500	5	25	48	30	2,20	81,50
645.0361	640.0320	290	17	16	32	32	3,30	192,50
645.0362	640.0330	400	24	23	48	40	6,50	270,90
645.0363	640.0350	700	35	42	87	50	17,00	604,50
645.2461	640.2415-17	440	17	16	32	32	3,30	192,50
645.2462	640.2420	270	17	16	32	32	3,30	192,50
645.2463	640.2430	310	24	23	48	40	6,50	270,90
645.2464	640.2450	660	35	42	87	50	17,00	604,50

Puller legs, forged ground steel

- For 2 arm and 3 arm basic universal puller
- Special tool steel



For pullers		B mm	D mm	E mm	F mm	G mm	kg	€
615.4101	620.4101+630.4101	45	2	9	18	10	40	9,90
615.4102	620.4102+630.4102	65	2	9	18	10	50	10,90
615.4103	620.4103+630.4103	80	2,3	12	25	13	100	11,90

Puller legs, forged ground steel

- For 2 arm and 3 arm basic universal puller
- Special tool steel

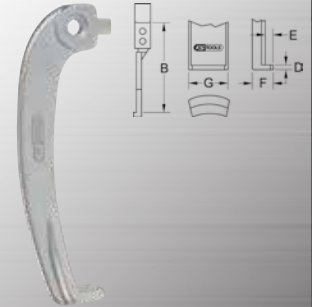

For pullers		B mm	D mm	E mm	F mm	G mm	kg	€
615.4301	620.4301+630.4301	80	4	12	26	13	130	11,90
615.4302	620.4302+630.4302	120	5	14	30	16	210	24,90
615.4303	620.4303+630.4303	160	6	18	35	20	350	34,50
615.4304	620.4304+630.4304	200	7	22	40	24	600	43,90

Puller legs

- For 2 arm and 3 arm pullers
- Special tool steel

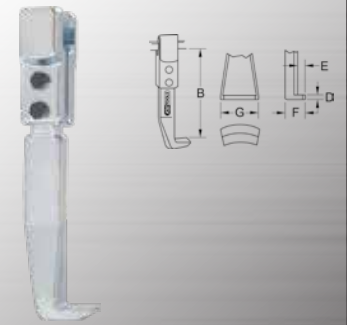

	B mm	max t	D mm	E mm	F mm	G mm	kg	€
615.0101	100	4,5	3	13	25	20	250	24,90
615.0102	150	6,5	4	16	35	25	650	37,50
615.0103	200	11,0	5	25	54	35	1650	63,50
615.0104	225	11,0	10	33	50	55	2150	110,50

Puller legs, extra long design

- For 2 arm and 3 arm pullers
- Special tool steel

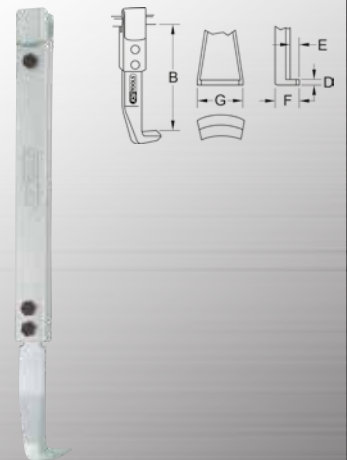

	B mm	D mm	E mm	F mm	G mm	kg	€
615.0501	200	3	13	25	20	0,50	28,90
615.0502	300	4	16	35	25	1,10	50,50
615.0503	300	5	25	54	35	2,50	84,50
615.0504	400	5	25	54	35	3,20	101,90
615.0505	500	5	25	54	35	3,90	106,90
615.0506	300	10	33	55	50	3,00	145,50
615.0507	400	10	33	55	50	3,70	169,50
615.0508	500	10	33	55	50	4,40	204,50

Quick adjustment puller legs, long design

- Quick release function
- For 2 arm and 3 arm pullers
- Special tool steel

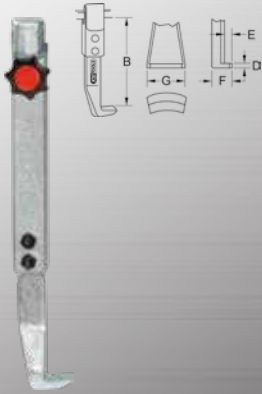

	B mm	D mm	E mm	F mm	G mm	kg	€
615.1051	225	5,0	25,0	54	35	0,52	103,90
615.1052	325	5,0	25,0	54	35	1,25	120,90
615.1053	425	5,0	25,0	54	35	3,25	138,50

Puller legs

- Legs are adjustable in the working depth
- For 2 arm and 3 arm pullers
- Special tool steel

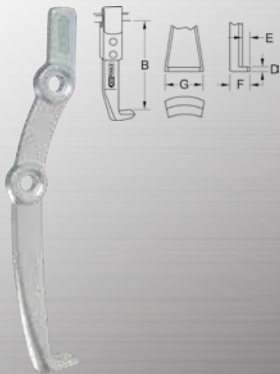

For pullers		B mm	D mm	E mm	F mm	G mm	kg	€
615.3401	620.3401+630.3401	130	2	11	23	16	150	21,50
615.3402	620.3402+630.3402	200	4,5	16	33	20	400	26,90

Special thread grease for puller and pusher spindles and nuts subjected high loads

- Lubricant for components subjected to high static loads, e.g. threaded spindles
- Prevents excessive wear and seizing
- Irregularities in the surface to be protected are completely filled
- Minimises the friction thanks to the closed surface
- Effective protection against corrosion
- Increases the service life of threaded spindles
- Ensures reliable function even at high temperatures up to max. 1200°C



		kg	€
980.1085	Special thread grease, gun	22	11,90
980.1090	Special thread grease, tube	5	3,50

Spindle

- Extremely robust spindle with inductively hardened thread
- Special tool steel

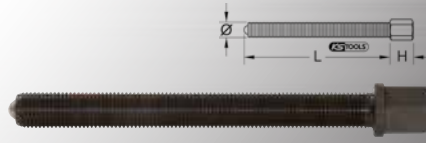

	mm	L mm	H mm	Ø mm	mm	kg	€
610.1401	12	150	15	10	M10	100	19,50
610.1402	14	190	20	12	M12	200	31,50
610.1701	17	60	21	14	M14 x 1,5	100	13,90
610.1702	17	130	21	14	M14 x 1,5	200	19,50
610.1703	17	200	21	14	M14 x 1,5	300	34,50
610.1704	17	250	21	14	M14 x 1,5	550	67,50
610.1705	17	60	20	16	M16 x 1,5	100	13,90
610.1706	17	70	20	16	M16 x 1,5	100	14,90
610.1707	17	90	20	16	M16 x 1,5	200	16,50
610.1901	19	70	20	18	M18 x 1,5	200	18,50
610.1902	19	130	20	18	M18 x 1,5	300	20,50
610.1903	19	170	20	18	M18 x 1,5	400	32,50
610.1904	19	240	20	18	M18 x 1,5	500	34,50
610.2201	22	110	23	21	G1/2"x14g	300	34,50
610.2202	22	160	23	21	G1/2"x14g	400	27,90
610.2203	22	175	23	21	G1/2"x14g	500	31,50
610.2204	22	210	23	21	G1/2"x14g	600	33,50
610.2205	22	235	23	21	G1/2"x14g	700	37,50
610.2206	22	270	23	21	G1/2"x14g	800	39,50
610.2701	27	180	35	26	G3/4"x14g	1000	50,50
610.2702	27	280	35	26	G3/4"x14g	1300	47,50
610.2703	27	360	35	26	G3/4"x14g	1700	79,50
610.3601	36	310	45	33	G1"x11g	2300	75,90
610.3602	36	360	45	33	G1"x11g	2650	112,50
610.3603	36	455	45	33	G1"x11g	3100	169,50
700.5612	21	113	27	16	M16 x 130	188	11,90

Hydraulic compression spindle

- Maximum pressure with little effort
- Special tool steel



	L mm	H mm	max t	Ø Body mm	Body mm	Pressure spindle mm	mm	kg	€
615.0001	260	23	12	41	UN 1.1/2"x16	M11x85	17	1,60	160,50
615.0002	410	55	12	32	G1/2"x14	M10x90	13	1,10	227,90
615.0003	410	55	12	36	G3/4"x14	M10x90	13	1,60	249,50
615.0004	460	80	15	41	G1"x11	M11x15x100	17	3,50	385,50

Spare traverse

- For hydraulic 2 arm puller
- Special tool steel



	max t	For pullers	kg	€
645.0210	10	640.0210	16,00	618,50
645.0215	15	640.0215	15,00	618,50
645.0217	17	640.0217	16,00	670,90
645.0220	20	640.0220	5,00	420,50
645.0230	30	640.0230	8,00	725,50
645.0250	50	640.0250	16,00	1017,50

Spare traverse

- For hydraulic 3 arm puller
- Special tool steel



	max t	For pullers	kg	€
645.0310	10	640.0310	4,00	188,50
645.0315	15	640.0315	3,50	188,50
645.0317	17	640.0317	4,50	154,50
645.0320	20	640.0320	7,00	472,90
645.0330	30	640.0330	11,50	1049,90
645.0350	50	640.0350	20,00	1485,50
645.2315	15	640.2315	10,00	669,90
645.2317	17	640.2317	12,50	600,50
645.2415	15	640.2415	10,00	669,90
645.2417	17	640.2417	12,50	600,50
645.2420	20	640.2420	15,00	600,50
645.2430	30	640.2430	27,00	861,50
645.2450	50	640.2450	27,00	861,50

Traverse arm for hydraulic gear puller

- For hydraulic 3 arm puller
- Special tool steel



	For pullers	kg	€
645.2316	640.2315-17	7,00	269,90
645.2416	640.2415-17	4,00	274,90
645.2421	640.2420	4,00	274,90
645.2431	640.2430	5,00	368,50
645.2451	640.2450	10,00	612,50

Universal clamping yoke

- For universal 2 arm puller
- Clamping yoke compresses the legs firmly
- Prevents slipping
- Special tool steel



	A mm	kg	€
615.5101	10-130	800	66,50

CYLINDER

Hydraulic press

- For mechanical pullers
- Power increase with the normal pressure spindle
- Maximum pressure with little effort
- Special tool steel



	L mm	H mm	max t	Hydraulic fit mm	Spindle mm	max t	kg	€
640.0160	150,0	75,0	8	8	M14x1,5 x 60	0,80	0,80	148,90
640.0165	180,0	90,0	15	12	M14x1,5 x 85	1,80	1,80	174,50

Spindle hydraulic cylinder

- Simply working with spring withdrawal
- Necessary minimal oil volume 120 cm³ = 0,12 l
- Maximum pressure with little effort
- Special tool steel

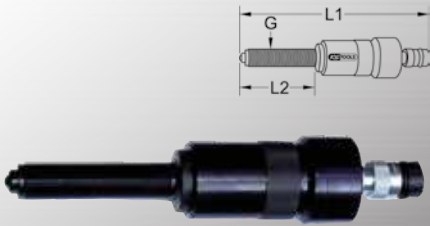

	L1 mm	L2 mm	Stroke mm	G	max t	kg	€	
640.0130	3/8" - 18 NPT	403	150,0	156,0	G1"x11g	17	4,50	457,90

Flat hydraulic cylinder

- Simply working with spring withdrawal
- Maximum pressure with little effort
- Special tool steel
- Locating bore 10t = dimension 36,6mm x Ø 7,1
- Locating bore 20t = dimension 49,3mm x Ø 10,0

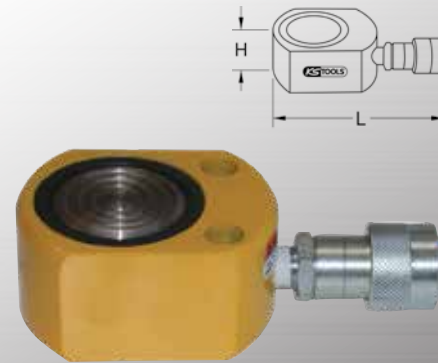

	L mm	H mm	Stroke mm	Minimal oil volume cm ³	max t	kg	€	
640.0140	3/8" - 18 NPT	140	42	12,0	18/0,018	10	1,60	528,50
640.0150	3/8" - 18 NPT	170	51	11,0	32/0,032	20	2,80	828,50

Single screw hydraulic cylinder

- Simply working with spring withdrawal
- Interchangeable pressure piece
- Maximum pressure with little effort
- Special tool steel

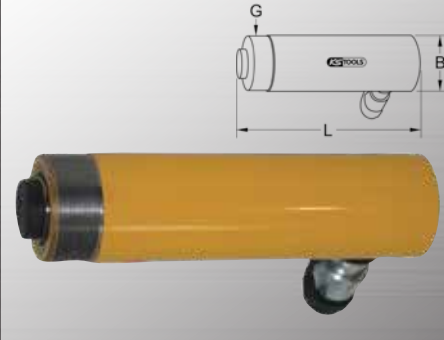

	L mm	B mm	Stroke mm	G	max t	kg	€	
640.0110	3/8" - 18 NPT	403	247	156,0	UNC2.1/4x14	10	4,00	955,50
640.0120	3/8" - 18 NPT	423	271	152,0	M68x2	15	7,00	1001,50

Hollow piston hydraulic cylinder with spindle

- Simply working with spring withdrawal
- Nickel plated centre tube
- Maximum pressure with little effort
- Special tool steel

Mounting thread at cylinder: 1.) 2 threaded hole with cylinder base (tube side) 2.) external thread: 20t=3-7/8"x12G30t=4-1/2"x12G50t=6-1/4"x12G

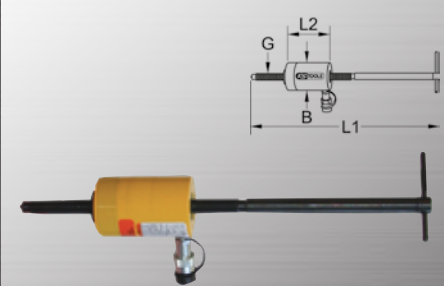

	L1 mm	L2 mm	B mm	Stroke mm	G	max t	kg	€	
640.0170	3/8" - 18 NPT	670	162,0	98	49,0	UNC1"-8	20	10,60	1382,50
640.0180	3/8" - 18 NPT	790	178,0	114	64,0	UNC1.1/4"-7	30	15,20	1728,50
640.0190	3/8" - 18 NPT	975	247,0	159	76,0	UNC1.5/8"-5,1/2"	50	40,50	3091,50

HYDRAULIC HAND PUMP

Hydraulic hand pump

- Single stage
- Reverse valve for advance and return stroke
- Safety valve for overload protection
- Includes pressure tube 1.8 meters
- Usable tank volume 2081cm³ = 2.081l



	L mm	B mm	H mm	Flow rate per 1/2 h cm ³	kg	€	
640.0010	3/8" - 18 NPT	585	133	119	2,62	9,00	1271,50

Pneumatic hydraulic pump

- Pneumatic working
- For simply agent press cylinders
- Safety valve for overload protection
- Includes pressure tube 1.8 meters
- Usable tank volume 2081cm³ = 2.081l
- Operating pressure max. 700 bar
- Output per stroke:
0.8 l/min up to 200 bar
0.1 l/min up to 700 bar



	L mm	B mm	H mm	kg	€	
640.0020	3/8" - 18 NPT	255	130	200	11,00	2180,90

Electric hydraulic pump

- Two stepped for simply agent press cylinders
- Safety valve for overload protection
- Usable tank volume 1900 cm³ = 1.9l
- Includes pressure tube 1.8 meters
- Motor specification 0.37kW - 220/230 V - 50/60 hertz, single phase (3.2 amps)
- 1. Step: max. 13 bar
- 2. Step: max. 700 bar
- Output per stroke:
1. Step: 3.31 l/min
2. Step: 0.32 l/min



	L mm	B mm	H mm	kg	€	
640.0030	3/8" - 18 NPT	244	244	362	14,00	5878,50

SAFETY COVERING FOIL

Safety covering foil

- Two ply welded
- High tearing resistance
- Variable adjustment
- UV resistant
- Temperature range of -25°C to +50°C



	B mm	L mm	max t	kg	€
610.0100	510,0	915,0	18	3,90	223,90

UNIVERSAL BELT PULLER

Universal belt pulley puller 3 arm

- For the damage free drawing off of pulley belts
- Universal suitable for several diameters and different hole divisions
- Less space requirement through compact method of building
- Suited for work on engines in the vehicle or removed
- Special tool steel

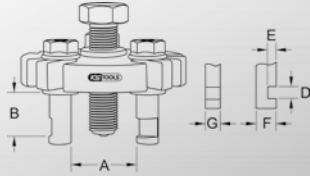

	A mm	B mm	max t	mm	D mm	E mm	F mm	G mm	g	€
150.3130	70	27	2,5	M15x1,5 x 71	17	10	6	11	820	34,90

accessories:

150.3133	Spare traverse for 150.3130	300
----------	-----------------------------	-----



Universal belt pulley puller 2 arm

- For grooved belt pulleys
- Draw off arms with locking device
- Clamping yoke compresses the legs firmly
- Prevents slipping
- Less space requirement through compact method of building
- Suited for work on engines in the vehicle or removed
- Special tool steel

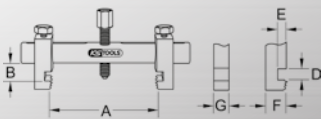

	A mm	B mm	max t	mm	D mm	E mm	F mm	G mm	g	€
150.3170	40-165	30	2,5	M12 x 75	17	10	9	18	1600	39,90

STEERING WHEEL PULLER

Universal steering wheel puller 2 arm for passenger cars

- Suitable for quick, clean and damage-free removal of the steering wheel
- Short and long hooks as well as pressure piece for spindle
- Suitable for universal use due to longitudinal grooves in the puller bridge
- Extremely robust spindle with inductively hardened thread
- Special tool steel

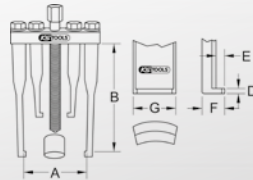

	A mm	B mm	max t	mm	D mm	E mm	F mm	G mm	g	€	
670.0201	90	135	2,5	M14x1,5 x 130	17	5	3,5	11	7,5	900	105,90



WINDSCREEN WIPER ARM PULLER

Universal windscreen wiper arm puller with fork

- With pulling yoke
- Ideally suited to the protective removal of windscreen wiper arms
- Pulling spindle with brass cap for damage-free support on the washer arm shaft
- Extremely robust spindle with inductively hardened thread
- Spindle guidance is carried out in a moving sleeve
- Prevents damage to the bodywork and the windscreen wiper arm
- With narrow socket for tight spaces
- Special tool steel

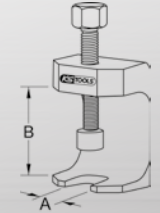

	A mm	B mm	mm	g	€
700.1198	23,5	48	8	240	28,90

Universal windscreen wiper arm puller with pulling yoke

- With pulling yoke
- Ideally suited to the protective removal of windscreen wiper arms
- Pulling spindle for damage-free support to the rear wiper blades
- Extremely robust spindle with inductively hardened thread
- Prevents damage to the bodywork and the windscreen wiper arm
- With adjustment dial for manual operation
- With narrow socket for tight spaces
- Special tool steel

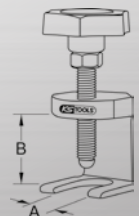

	A mm	B mm	mm	mm	g	€
700.1193	16	28	M8 x 45	11	140	7,50

Universal windscreen wiper arm puller with pulling yoke

- Heavy execution
- With pulling yoke
- Ideally suited to the protective removal of windscreen wiper arms
- Spindle end with brass cap to prevent damage to the windscreen wiper arm
- Extremely robust spindle with inductively hardened thread
- Spindle guidance is carried out in a moving sleeve
- Prevents damage to the bodywork and the windscreen wiper arm
- With narrow socket for tight spaces
- Special tool steel

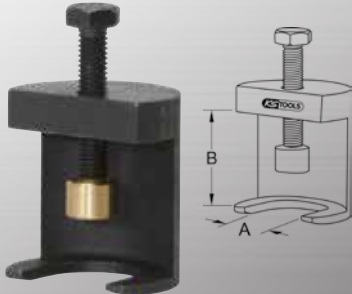

	A mm	B mm	mm	mm	kg	€
700.1191	26	48	M8 x 75	13	450	36,50

Universal windscreen wiper arm puller with pulling yoke

- Heavy execution
- With pulling yoke
- Ideally suited to the protective removal of windscreen wiper arms
- Spindle end with brass cap to prevent damage to the windscreen wiper arm
- Extremely robust spindle with inductively hardened thread
- Spindle guidance is carried out in a moving sleeve
- Prevents damage to the bodywork and the windscreen wiper arm
- With narrow socket for tight spaces
- Special tool steel

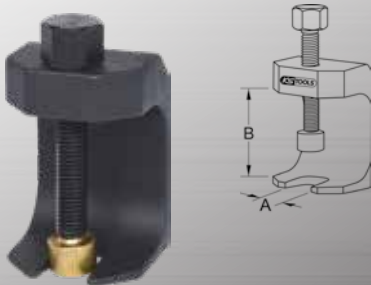

	A mm	B mm	mm	mm	kg	€
700.1192	16	41	M10 x 80	17	510	49,50

Universal windscreen wiper arm puller 2 arm

- 2-jaw
- Ideally suited to the protective removal of windscreen wiper arms
- Hollow puller spindle for damage-free support on the wiper arm shaft with washer nozzle
- Extremely robust spindle with inductively hardened thread
- Prevents damage to the bodywork and the windscreen wiper arm
- Internal square drive adaptor to DIN 3120 / ISO 1174
- Special tool steel

Application range: especially for VAG rear windscreen wiper with integrated washer nozzle



	A mm	B mm	mm	mm	mm	mm	mm	mm	kg	€
700.1185	10-60	34	M12x1,25 x 34	17	3	5	14	15	1,00	28,90

Universal windscreen wiper arm puller set

- Ideally suited to disassembly of windscreen wiper arms
- Includes impact hammer puller
- Universally fitting puller set suitable for approx. 450 windscreen wipers, 300 vehicles and 30 car brands
- Self-stiffening or recessed built-in washer arms are quickly disassembled with this set
- Alternatively can be used mechanically or with an impact spindle
- Prevents damage to the bodywork and the windscreen wiper arm
- Special tool steel
- In durable plastic storage case



		kg	€
700.1240	13 pcs Universal windscreen wiper arm puller set	3,81	276,50

consists of:

		kg
700.1231	Slide hammer with fork spanner	1130
700.1232	Spindle, 95mm, M12	170
700.1233	Fork #1, opening 22mm, H=50mm	110
700.1234	Fork #2, opening 25mm, H=50mm	140
700.1235	Fork #3, opening 16mm, H=60mm	150
700.1236	Fork #4, opening 25mm, H=41mm	110
700.1237	Fork #5, opening 30mm, H=50mm	150
700.1238	Fork #6, opening 20mm, H=50mm	100
700.1239	Fork #7, opening 17mm, H=55mm	100
700.1241	Fork #8, opening 16mm, H=80mm	170
700.1242	Universal 2 arm wiper arm puller set, 6 pcs	690
700.1243	Spindel extension for 700.1232 and 700.1242	20
700.1244	Hollow spindle adaptor for 700.1232 and 700.1242	20

BALL JOINT PULLERS

Vibro-Impact Universal Ball Joint Puller Bell 30 x 58 mm

- Pressure pieces in the spindle rotating mouted
- Trapezoidal spindle
- High release force due to rotary shock pulse with impact wrench
- Impact screws create pressure and vibration at the same time, through which the secure ball joint connections and quickly and safely removed
- Less space required
- Cast forged execution
- With inspection panel
- Special tool steel

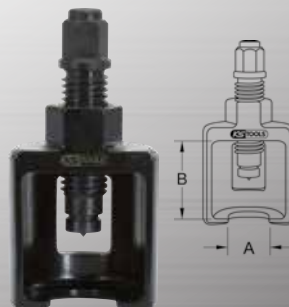

	A mm	B mm	mm	mm	kg	€
450.0060	30	58	22	18	1,10	158,50

Vibro-Impact Universal Ball Joint Puller Bell 32 x 90 mm

- Pressure pieces in the spindle rotating mouted
- Trapezoidal spindle
- High release force due to rotary shock pulse with impact wrench
- Impact screws create pressure and vibration at the same time, through which the secure ball joint connections and quickly and safely removed
- Less space required
- Cast forged execution
- With inspection panel
- Special tool steel



	A mm	B mm	mm	mm	kg	€
450.0061	32	90	24	25	2,51	238,90

Vibro-Impact Universal Ball Joint Puller Bell 39 x 58 mm

- Pressure pieces in the spindle rotating mouted
- Trapezoidal spindle
- High release force due to rotary shock pulse with impact wrench
- Impact screws create pressure and vibration at the same time, through which the secure ball joint connections and quickly and safely removed
- Less space required
- Cast forged execution
- Without inspection panel
- Special tool steel

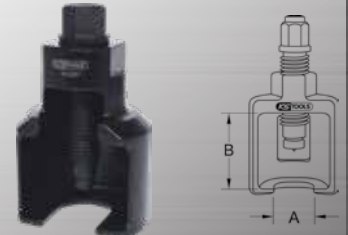

	A mm	B mm	mm	mm	kg	€
450.0062	39	58	24	25	2,83	256,90

Vibro-Impact Universal Ball Joint Puller Bell 32 x 40 mm

- Pressure pieces in the spindle rotating mouted
- Trapezoidal spindle
- High release force due to rotary shock pulse with impact wrench
- Impact screws create pressure and vibration at the same time, through which the secure ball joint connections and quickly and safely removed
- Less space required
- Cast forged execution
- With inspection panel
- Special tool steel

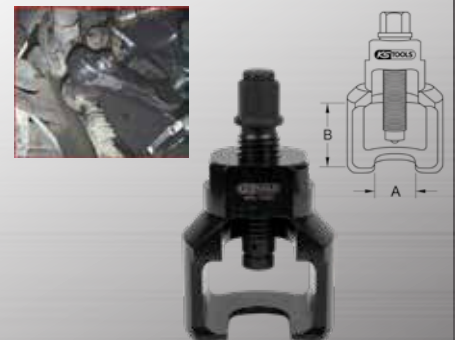

	A mm	B mm	mm	mm	kg	€
460.1020	32,0	40,0	22,0	19,0	1,50	225,90

Vibro-Impact Universal Ball Joint Puller Bell 39 x 60 mm

- Pressure pieces in the spindle rotating mounted
- Trapezoidal spindle
- High release force due to rotary shock pulse with impact wrench
- Impact screws create pressure and vibration at the same time, through which the secure ball joint connections and quickly and safely removed
- Less space required
- Cast forged execution
- With inspection panel
- Special tool steel

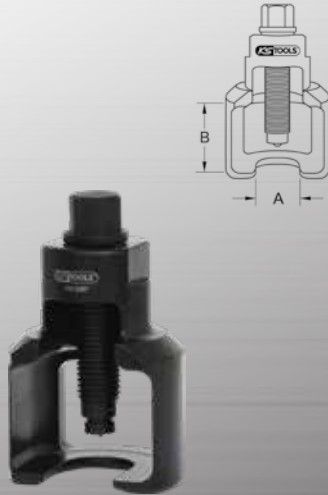

	A mm	B mm	mm	mm	kg	€
450.0066	39	60	26	39	3,80	238,90

Vibro-Impact Universal Ball Joint Puller Bell 39 x 59 mm

- Ball mounted rotatably in the spindle
- Trapezoidal spindle
- High release force due to rotary shock pulse with impact wrench
- Impact screws create pressure and vibration at the same time, through which the secure ball joint connections and quickly and safely removed
- Less space required
- Cast forged execution
- With inspection panel
- Special tool steel

Application range: Universally applicable for commercial vehicles 3.5-8.8t

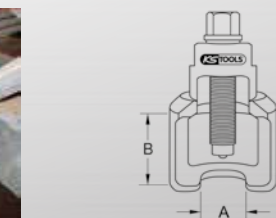

	A mm	B mm	mm	mm	kg	€
460.0475	32,0	90,0	24,0	26,0	2,70	202,50

Vibro-Impact Universal Ball Joint Puller Bell 35 x 60 mm

- Ball mounted rotatably in the spindle
- Trapezoidal spindle
- High release force due to rotary shock pulse with impact wrench
- Impact screws create pressure and vibration at the same time, through which the secure ball joint connections and quickly and safely removed
- Less space required
- Cast forged execution
- With inspection panel
- Special tool steel

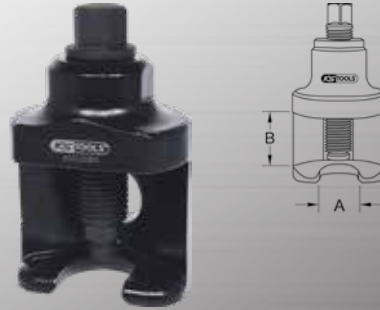

	A mm	B mm	mm	mm	kg	€
450.0085	35	60	M27 x 130	24	2,52	367,50

Universal ball joint ejector

- For many automobiles and commercial vehicles
- Special tool steel

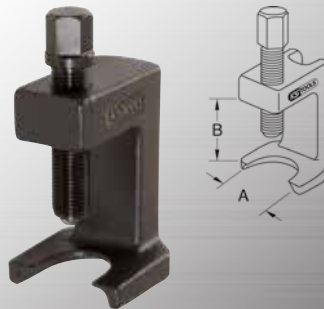

	A mm	B mm	max t	mm	mm	kg	€
670.0061	23	55	4	17	M16x1,5x60	800	52,50
670.0062	28	55	4	17	M16x1,5x60	800	57,90
670.0063	34	63	4	19	M18x1,5x70	900	57,90

Universal ball joint extractor

- Tools for pushing out support and guide joints as well as
- Tie rod joint pin consisting of steering lever, axle beam/arm and stabilizers
- Universally applicable in the range of passenger cars to vans
- Compact and stable design
- Extremely robust spindle with inductively hardened thread and pressure ball
- In durable plastic storage case



			mm	mm	kg	€
670.0060	3 pcs	23 - 28 - 34 mm			2,90	172,50

Universal ball joint separator

- For many automobiles and commercial vehicles
- Special tool steel



	A mm	B mm	C mm	max N·m	mm	mm	kg	€
670.0101	18	40	40	50	M14x1,5x60	17	0,30	36,50
670.0102	25	50	50	120	M16x1,5x60	17	0,70	50,50
670.0103	29	60	60	160	M18x1,5x75	19	1,00	64,50
670.0104	40	80	80	280	G1/2"x14gx110	22	2,10	83,50
670.0105	45	100	90	400	G3/4"x14gx125	27	2,80	104,90

Universal ball joint separator

- For a professional disassembly of the ball joints on the upper wishbone
- Optimal positioning through compact design
- Special tool steel

Application range: Volkswagen T4 bus / Multivan / California / pickup etc.



	A mm	B mm	C mm	max N·m	mm	mm	kg	€
670.0106	56	80	100	280	G1/2"x14gx110	22	2,10	124,50

Universal ball joint extractor

- Robust model for loosening the track heads and push pole heads
- Optimal positioning through compact design and slim fork piece
- Special tool steel



	A mm	B mm	C mm	mm	mm	kg	€
450.0075	45	75	63	24	M22 x 135	1,63	106,90
450.0076	55	100	76	24	M22 x 135	1,84	109,50

Universal ball joint separator 2 stage adjustable

- Separator 2 stage adjustable
- Ideal for confined spaces
- Spindle hexagonal with additional drive point
- Forged
- Special tool steel



	A mm	B mm	mm	mm	kg	€
700.5610	24	0-55	M16 x 90	20	1,05	46,50

Universal ball joint separator 4 stage adjustable

- Separator 4 stage adjustable
- Spindle hexagonal with additional drive point
- Forged
- Special tool steel
- Stage 1: 24 mm
- Stage 2: 30 mm
- Stage 3: 40 mm
- Stage 4: 45 mm

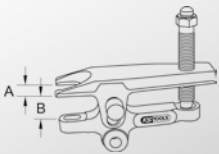

	A mm	B mm	mm	mm	kg	€
700.5630	22	24-45	M14 x 105	18	1,50	86,90

Universal ball joint separator

- Extra flat execution
- Forged
- Special tool steel

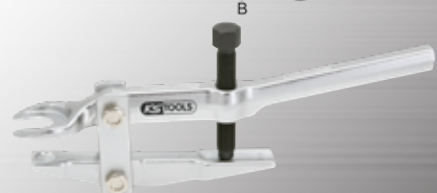
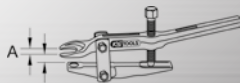

	A mm	B mm	mm	mm	kg	€
700.5620	18	20-37	M14 x 85	16	0,97	40,90

Universal ball joint separator

- Extra strong execution
- Forged
- Special tool steel

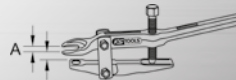

	A mm	B mm	mm	mm	kg	€
700.5625	20	20-37	M12 x 85	16	1,07	43,90

Universal ball joint extractor

- Robust model for loosening the track heads and push pole heads
- Optimal positioning through compact design and slim fork piece
- Adjustment of the clamp by means of the spindle
- Special tool steel

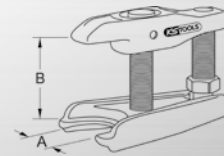

	A mm	B mm	mm	mm	kg	€
450.0070	32	75	M22 x 90	30	2,49	92,50
450.0071	45	80	M22 x 90	30	2,61	96,50

Ball joint puller for commercial vehicle, mechanical

- Massive execution for loosening the track heads and push pole heads
- Enormous power through lever transmission
- Special tool steel



	A mm	B mm	mm	mm	kg	€
450.0051	36	70	M24x3x160	34	4,34	243,90

Hydraulic universal ball joint separator

- Massive execution for loosening the track heads and push pole heads
- for fork-opening diameters of up to 36 mm
- Enormous power through lever transmission
- Excellent power transfer
- Special tool steel



	A mm	B mm	max t	mm	mm	kg	€
450.0050	36	70	10	17	1.1/2"x16G	6,55	421,50

Universal ball joint separator

- Massive execution for loosening the track heads and push pole heads
- suitable for many heavy trucks, buses and low-floor buses
- Enormous power through lever transmission
- including 3 exchangeable pressure peaks
- Special tool steel



	A mm	B mm	mm	kg	€
460.1030	39,0	70,0	19,0	6,00	370,50

Universal ball joint separator

- For separating the ball plug when removing the ball joints
- Suitable for many vehicles + transporter
- Also suitable for aluminum undercarriages
- Special tool steel

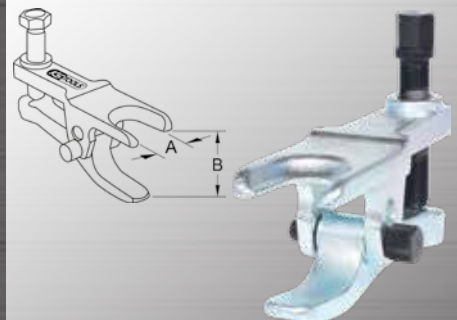

	A mm	B mm	max t	mm	mm	kg	€
670.0121	24	50	3,5	17	M16x1,5x70	1,40	105,90
670.0122	24	60-80	3,5	17	M15x1,5x90	1,80	144,50

Universal ball joint separator 2 stage adjustable

- Separator 2 stage adjustable
- Ideal for confined spaces
- Extremely high clamping range
- Spindle hexagonal with additional drive point
- Forged
- Special tool steel

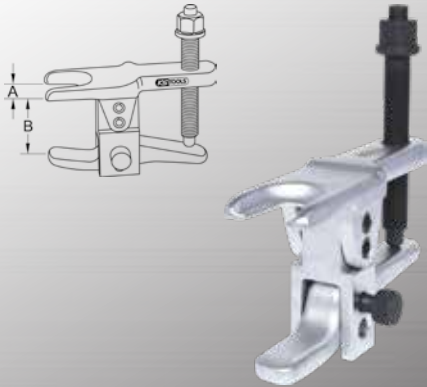

	A mm	B mm	mm	mm	kg	€
700.5615	18-24	23-110	M16 x 130	16	1,20	71,90

Universal ball joint separator

- For separating the ball plug when removing the ball joints
- Suitable for many vehicles
- Special tool steel

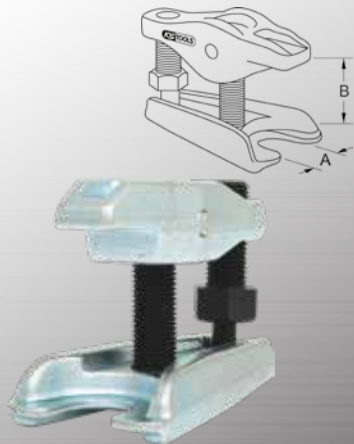

	A mm	B mm	max t mm	mm	mm	kg	€
670.0111	18-22	50	3,5	19	M14x1,5x48	0,90	41,90

Universal ball joint separator

- For separating the ball plug when removing the ball joints
- Suitable for many vehicles + moderately heavy trucks
- Special tool steel

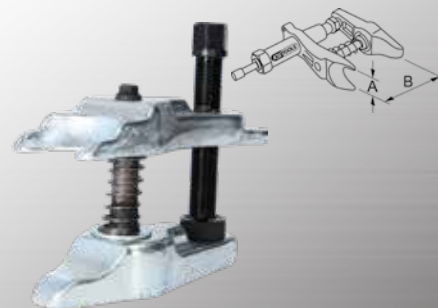

	A mm	B mm	max t mm	mm	mm	kg	€
670.0131	36	90	10	22	G1/2"x14gx110	3,70	160,50

Universal ball joint separator

- For separating the ball plug when removing the ball joints
- Suitable for many heavy trucks, buses and low-floor buses
- For bolts Ø 35.0 - 45.0 mm
- Special tool steel



	A mm	B mm	max t mm	mm	mm	kg	€
670.0161	45	115	20	27	G3/4"x14gx125	6,40	276,50

Hydraulic universal ball joint separator

- For separating the ball plug when removing the ball joints
- Suitable for many vehicles + moderately heavy trucks
- For bolts Ø 27.0 - 36.0 mm
- Special tool steel

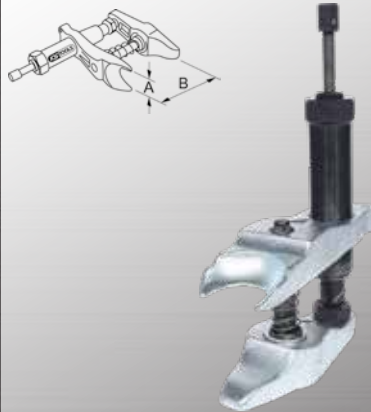

	A mm	B mm	max t mm	mm	mm	kg	€
670.0141	36	90	10	17	1.1/2"x16G	4,70	316,90

Universal ball joint separator without hydraulic cylinder

- For separating the ball plug when removing the ball joints
- Suitable for many vehicles + moderately heavy trucks
- For bolts Ø 27.0 - 36.0 mm
- Special tool steel
- For use with 640.0140

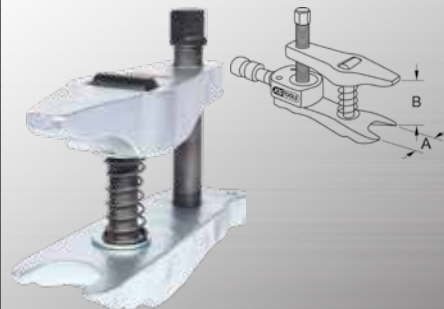

	A mm	B mm	max t mm	Adjusting screw mm	Ambose spindle mm	mm	kg	€
670.0151	36	90	10	M18x1,5x120	G1/2"x14gx110	22	3,50	160,50

Hydraulic universal ball joint separator

- For separating the ball plug when removing the ball joints
- Suitable for many heavy trucks, buses and low-floor buses
- For bolts Ø 35.0 - 45.0 mm
- Special tool steel

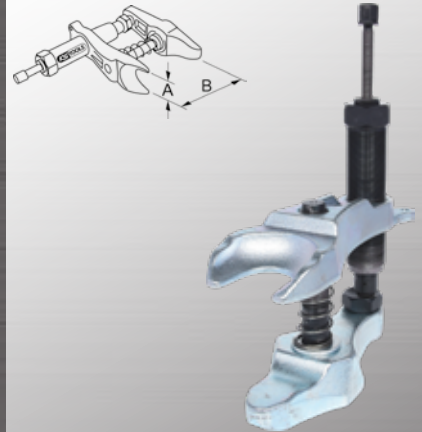

	A mm	B mm	max t mm	mm	mm	kg	€
670.0171	45	115	20	17	M14x1,5x50	7,00	421,50

Universal ball joint separator without hydraulic cylinder

- For separating the ball plug when removing the ball joints
- Suitable for many heavy trucks, buses and low-floor buses
- For bolts Ø 35.0 - 45.0 mm
- Special tool steel
- For use with 640.0140 / 640.0150



	A mm	B mm	max t mm	mm	mm	kg	€
670.0181	45	115	20	27	G3/4"x14gx125	6,00	262,50



Universal ball joint remover set with changeable forks

- With interchangeable forks Ø 20/22/24/27/30 mm
- For separating the ball plug when removing the ball joints
- Quick changes of the individual pressure forks due to the spring breaker system
- Maximum separation height: 125.0 mm
- In durable plastic storage case



			kg	€
450.0970	7 pcs	Universal ball joint remover set with changeable forks	6,00	527,50

consists of:

			kg	€
450.0971	Universal ball pin ejector device	2000		
450.0972	Pressure spindle	380		
450.0973	Fork, Ø 20 mm	520		
450.0974	Fork, Ø 22 mm	520		
450.0975	Fork, Ø 24 mm	520		
450.0976	Fork, Ø 27 mm	520		
450.0977	Fork, Ø 30 mm	520		

Wheel hub impact puller

- suitable for removing 4 and 5-hole wheel hubs
- Holes from 100 to 150 mm
- With 1.7 kg impact force
- Optimal grip with plastic handle
- Ideally used when replacing wheel bearings
- Simple handling
- Special tool steel



	Rim diameter Ø mm	Bolt Ø mm	Hammer Ø mm	Slide rail Ø mm	Adaptor thread mm	kg	€
670.0001	100-150	max. 14	60	16	M16 x 1.5	3,70	167,90

WHEEL HUB EXTRACTOR & DRIVE SHAFT EJECTOR

Flange extractor set

- In order to separate the flanges in pipes to enable gasket changing or maintenance works
- For screws M16 - M24
- Special tool steel



	Ø mm	mm	mm	kg	€	
670.0251	2 pcs	80-250	M24x-1,5x110	24	5,60	317,90

Separating and assembly fork

- For quick loosening of track and steering rod ends steering arms and additional controlling parts
- Ideal for confined spaces
- Special tool steel

Caution: The separating and mounting fork damages the dust sleeve



	A mm	L mm	kg	€
670.0091	18	330,0	0,90	47,50
670.0092	23	330,0	0,90	51,50
670.0093	31	330,0	1,10	53,50
670.0094	35	330,0	1,30	58,90
670.0095	45	330,0	1,50	67,50

Universal wheel hub extractor set

- For bolt circle diameter up to 250 mm
- Clamp foot hole for bolts 14 mm, 18 mm + 22 mm
- Special tool steel



			kg	€
670.0013	5 pcs	Universal wheel hub extractor set	3,60	165,90

Universal wheel hub extractor set

- For bolt circle diameter up to 250 mm
- Clamp foot hole for bolts 14 mm, 18 mm + 22 mm
- Special tool steel



			kg	€
670.0014	6 pcs	Universal wheel hub extractor set	4,10	186,50

Universal wheel hub extractor set

- For bolt circle diameter up to 250 mm
- Clamp foot hole for bolts 14 mm, 18 mm + 22 mm
- Special tool steel



			kg	€
670.0015	7 pcs	Universal wheel hub extractor set	4,60	205,50

accessories:

			kg	€
670.0017	Traverse bar for weehl hub extractor set	820		39,50
670.0018	Puller leg +reception ring Ø14mm + Ø18mm	540		46,50
670.0019	Reception ring Ø 14mm	22		11,90
670.0020	Reception ring Ø 18mm	16		11,90
610.2701	Spindle, 27mm, G3/4"x14Gx180mm	1000		50,50

Universal wheel bearing puller and drive shaft puller, hydraulic

- Special tool for expressing the joint hubs or drawing off of the wheel hub
- Massive tool, made out of a one piece
- Special tool steel
- In durable plastic storage case



			kg	€
700.1400	11 pcs	Universal wheel bearing puller and drive shaft puller, hydraulic	9,34	356,50

consists of:

			kg	€
700.1400-1	Hydraulic spindle 10 t, AG 1.1/2"x16G	1,34		
700.1400-2	Disc traverse, 100mm	0,92		
700.1400-3	Puller pull arm set, 5 pcs	0,50		
700.1400-4	Impact socket 30mm, L=200mm	0,94		
700.1400-5	Impact spindle	2,02		
700.1400-7	Extension small	0,06		

Wheel hub and bearing dismantling set

- Special tool for expressing the joint hubs or drawing off of the wheel hub
- Massive tool, made out of a one piece
- Special tool steel



			kg	€
700.1410	7 pcs	Wheel hub and bearing dismantling set	4,80	353,50

consists of:

			kg
700.1400-1	Hydraulic spindle 10 t, AG 1.1/2"x16G	1,34	
700.1411	Wheel hub puller without spindle	2,55	
700.1412	Conical ring set, 5 pcs	0,15	

DRAW OFF LINING

Draw off lining

- For drawing off the shoulder housings interior ring of light machines, motor parts and other machine parts
- Special tool steel

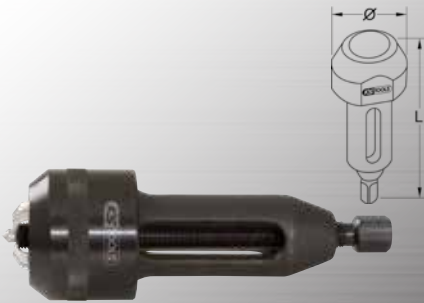

	Ø mm	L mm	max N·m	mm	mm	kg	€
670.0221	5-32	135	60	17	M14x1,5 x 130	1,40	194,90

STUD BOLT PULLER

Stud bolt puller

- For screwing in or extracting out stud bolts
- Right and left clamping function
- also for lengthy stud bolts
- Special tool steel



	Ø mm	max N·m	mm	kg	€
670.0231	5 - 15	120	19 mm	360	41,90
670.0232	10 - 19	120	19 mm	400	49,50
670.0233	18 - 28	120	19 mm	450	59,90

Stud bolt puller

- For screwing in or extracting out stud bolts
- Right and left clamping function
- also for lengthy stud bolts
- Special tool steel



	Ø mm	max N·m	mm	kg	€
670.0241	5 - 20	120	19 mm	400	72,90

Eccentric clamping and turning device

- For the removal and rotation of the round or hexagonal track rod joints (steering and wheel end)
- Due to the knurled eccentric cam it allows from optimal grip even at the joints without drive (round)
- For use on the workbench or directly on the vehicle
- Additional stopper prevents slipping during the splitting process
- Special tool steel



	Ø mm	Ø mm	kg	€
150.1640	23-45	31-35	300	86,90

Eccentric clamping and turning device

- For the removal and rotation of the round or hexagonal track rod joints (steering and wheel end)
- Due to the knurled eccentric cam it allows from optimal grip even at the joints without drive (round)
- For use on the workbench or directly on the vehicle
- Additional stopper prevents slipping during the splitting process
- Special tool steel



	Ø mm	Ø mm	kg	€
150.1642	25-55	25-46	800	86,90



Stud bolt puller

- External hexagon drive
- With right and left hand clamping function
- Safe clamping due to 3 rollers
- Stud screws can be screwed in or out without using counter nuts on the bolt
- Also for extra long studs that will go through the through socket
- Mirror polished
- Chrome vanadium



		mm	mm	kg	€
152.1005	M5	3/8"	19 mm	150	11,90
152.1006	M6	1/2"	21 mm	160	12,90
152.1007	M7	1/2"	21 mm	160	12,90
152.1008	M8	1/2"	21 mm	170	12,90
152.1010	M10	1/2"	21 mm	180	13,90
152.1012	M12	1/2"	21 mm	184	13,90
152.1014	M14		21 mm	275	14,90

Screw bolt puller set

- Square drive adaptor to DIN 3120 / ISO 1174 with ball lock
- External drive hexagonal socket 21.0 mm
- With right and left hand clamping function
- Safe clamping due to 3 rollers
- allows quick and effortless insertion and removal of studs, dowel screws, threaded rods etc.
- Stud screws can be screwed in or out without using counter nuts on the bolt
- Also for extra long studs that will go through the through socket
- Mirror polished
- Chrome vanadium
- In durable plastic storage case



			kg	€
152.1100	4 pcs	M6 - M8 - M10 - M12	0,79	55,90

Screw bolt puller set

- External hexagon drive
- With right and left hand clamping function
- Safe clamping due to 3 rollers
- Stud screws can be screwed in or out without using counter nuts on the bolt
- Also for extra long studs that will go through the through socket
- Mirror polished
- Chrome vanadium
- In durable plastic storage case



			kg	€
152.1101	7 pcs	M5 - M6 - M7 - M8 - M10 - M12 - M14	1,50	49,90

Screw extractor set

- For screws from M3 - M18
- Enable the loosening of screws and bolts with turned off heads
- Conical tapered spiral
- In durable plastic case

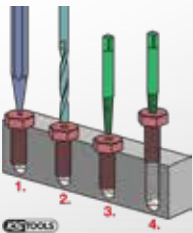

			kg	€
150.1330	6 pcs	M3-M6 - M6-M8 - M8-M11 - M11-M14 - M14-M18 - M18-M24	64	17,50

NUT SPLITTER

Mechanical nut splitter set

- For splashing on tight and overtightened nuts without damaging the threaded bolt
- Suitable for nuts to a tensile strength class 6
- Special tool steel



			kg	€
700.1180	4 pcs	Mechanical nut splitter set	1,58	195,90

consists of:

			kg	€
700.1181	Nut splitter 9 - 12 mm, drive 12 mm		90	
700.1182	Nut splitter 12 - 16 mm, drive 14 mm		170	
700.1183	Nut splitter 16 - 22 mm, drive 19 mm		380	
700.1184	Nut splitter 22 - 27 mm, drive 21 mm		660	

Hydraulic nut splitter set

- For splashing on tight and overtightened nuts without damaging the threaded bolt
- Working range 7.0 - 36 mm
- Induction hardened in the cutting area
- Suitable for nuts to a tensile strength class 10
- Excellent power transfer
- Special tool steel
- In durable plastic storage case



			kg	€
700.1170	7 pcs	Hydraulic nut splitter set	5,00	306,50

consists of:

			kg	€
700.1150	Hydraulic nut splitter 7.0 - 21.0 mm		700	
700.1163	Nut splitter		3600	
700.1151	Replacement chisel small		50	
700.1152	Replacement plate small		50	
700.1161	Replacement chisel large		100	
700.1162	Replacement plate large		100	
151.2073	Hexagon key 3/8" for replacement plate large		110	

Hydraulic nut splitter

- Small execution
- Suitable for nuts to a tensile strength class 10
- Work pressure max. 5 t
- Suitable for narrow spaces



	mm	L mm	kg	€
700.1150	7-21	210,0	700	85,50

Hydraulic nut splitter

- Small execution
- Suitable for nuts to a tensile strength class 10
- Compressive force max. 15 t
- Suitable for narrow spaces
- Exchangeable chisel

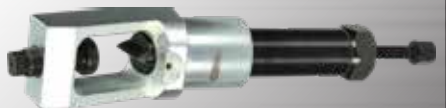

	mm	Length mm	kg	€
630.0022	22-36	290,0	2,90	953,50

Hydraulic nut splitter set

- Large execution
- Suitable for nuts to a tensile strength class 10
- Work pressure max. 13 t
- In durable plastic storage case



			kg	€
700.1160	4 pcs	22 - 36 mm; M14 - M24	3,80	194,90

consists of:

			kg	€
700.1161	Replacement chisel large		100	
700.1162	Replacement plate large		100	
700.1163	Nut splitter		3600	
151.2073	Hexagon key 3/8" for replacement plate large		110	

700.1200

Hydraulic universal 2 + 3 arm puller set

- Less risk of slippage due to automatically closing pulling arm
- 8 length positions possible
- Extremely robust spindle with inductively hardened thread
- Lower power usage
- Special tool steel



22
pcs

304,90 €



700.1300

Universal 2 + 3 arm puller set

- Slim hooks
- Ideal for confined spaces
- Through reversing the arms internal and external applications are possible
- Wide range of arms and hydraulic spindles available
- Extremely robust spindle with inductively hardened thread

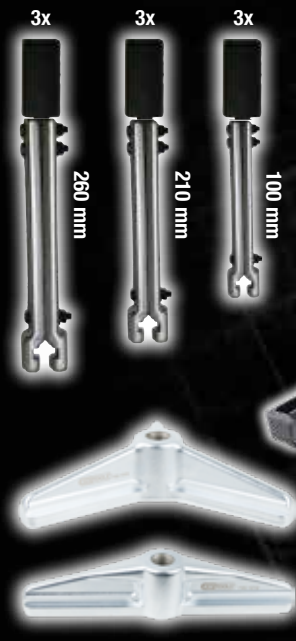
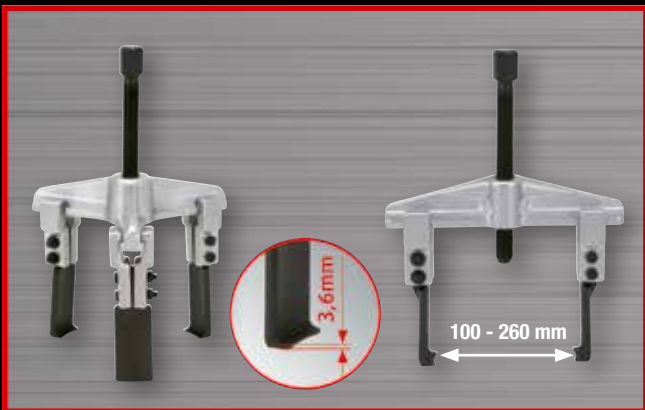

12
pcs

298,50 €



Your Local Distributor:



KS Tools Werkzeuge - Maschinen GmbH
 Seligenstädter Grund 10 - 12
 D-63150 Heusenstamm

GERMANY
 Tel.: +49(0) 61 04 49 74-0
 Fax: +49(0) 61 04 49 74-11
 e-mail: kstools@kstools.de
 www.kstools.com

